



2023

**OWNER'S MANUAL
MANUEL DU PROPRIÉTAIRE**

YZ250X

⚠ Read this manual carefully before operating this vehicle.

⚠ Il convient de lire attentivement ce manuel avant la première utilisation du véhicule.

YZ250XP

BRY-28199-70

 **Read this manual carefully before operating this vehicle. This manual should stay with this vehicle if it is sold.**

 **Il convient de lire attentivement ce manuel avant la première utilisation du véhicule. Le manuel doit être remis avec le véhicule en cas de vente de ce dernier.**



2023

OWNER'S MANUAL

YZ250X

⚠ Read this manual carefully before operating this vehicle.

YZ250XP

BRY-28199-70-E0



Read this manual carefully before operating this vehicle. This manual should stay with this vehicle if it is sold.

Reporting safety defects (For Canada)

If you believe that your vehicle has a defect which could cause a crash or could cause injury or death, you should immediately inform Transport Canada in addition to notifying Yamaha Motor Canada Ltd, Canada. If Transport Canada receives similar complaints, it may open an investigation, and if it finds that a safety defect exists in a group of vehicles, it may order a recall and remedy campaign. However, Transport Canada cannot become involved in individual problems between you, your dealer, or Yamaha Motor Canada Ltd., Canada.

To contact Transport Canada, you may call Defect Investigations and Recall Division at 819-994-3328 or toll free 1-800-333-0510, go to www.tc.gc.ca or email: mvs-sa@tc.gc.ca or write to Transport Canada, 330 Sparks Street Ottawa, ON, K1A 0N5.

You can also obtain other information about motor vehicle safety from www.tc.gc.ca.

EAM20080

**YZ250XP
OWNER'S MANUAL
©2023 by Yamaha Motor Co., Ltd.
First edition, April 2022
All rights reserved.
Any reprinting or unauthorized use
without the written permission of
Yamaha Motor Co., Ltd.
is expressly prohibited.
Printed in Japan.**

IMPORTANT

Congratulations on your purchase of a Yamaha YZ series. This model is the culmination of Yamaha's vast experience in the production of pacesetting racing machines. It represents the highest grade of craftsmanship and reliability that have made Yamaha a leader.

This manual explains operation, inspection, basic maintenance and tuning of your machine. If you have any questions about this manual or your machine, please contact your Yamaha dealer.

TIP

- Yamaha continually seeks advancements in product design and quality. Therefore, while this manual contains the most current product information available at the time of printing, there may be minor discrepancies between your machine and this manual. If you have any questions concerning this manual, please consult your Yamaha dealer.
- This manual is intended for those who have basic knowledge and skill concerning the servicing of Yamaha motorcycles (e.g., Yamaha dealers, service engineers, etc.). Those who have little knowledge and skill concerning servicing are requested not to undertake inspection, adjustment, disassembly, or reassembly only by reference to this manual. It may lead to servicing trouble and mechanical damage.



WARNING

PLEASE READ THIS MANUAL CAREFULLY AND COMPLETELY BEFORE OPERATING THIS MACHINE. DO NOT ATTEMPT TO OPERATE THIS MACHINE UNTIL YOU HAVE ATTAINED A SATISFACTORY KNOWLEDGE OF ITS CONTROLS AND OPERATING FEATURES AND UNTIL YOU HAVE BEEN TRAINED IN SAFE AND PROPER RIDING TECHNIQUES. REGULAR INSPECTIONS AND CAREFUL MAINTENANCE, ALONG WITH GOOD RIDING SKILLS, WILL ENSURE THAT YOU SAFELY ENJOY THE CAPABILITIES AND THE RELIABILITY OF THIS MACHINE.

IMPORTANT MANUAL INFORMATION

Particularly important information is distinguished in this manual by the following notations.

	<p>This is the safety alert symbol. It is used to alert you to potential personal injury hazards. Obey all safety messages that follow this symbol to avoid possible injury or death.</p>
WARNING	<p>A WARNING indicates a hazardous situation which, if not avoided, could result in death or serious injury.</p>
NOTICE	<p>A NOTICE indicates special precautions that must be taken to avoid damage to the vehicle or other property.</p>
TIP	<p>A TIP provides key information to make procedures easier or clearer.</p>

TABLE OF CONTENTS

GENERAL INFORMATION	1
SPECIFICATIONS	2
PERIODIC CHECKS AND ADJUSTMENTS	3
CHASSIS	4
ENGINE	5
ELECTRICAL SYSTEM	6
TROUBLESHOOTING	7
TUNING	8

GENERAL INFORMATION

SAFETY INFORMATION	1-1
FOR SAFETY, BE SURE TO OBEY THE FOLLOWING:	1-1
LOCATION OF IMPORTANT LABELS	1-4
DESCRIPTION	1-7
IDENTIFICATION	1-8
VEHICLE IDENTIFICATION NUMBER	1-8
ENGINE SERIAL NUMBER	1-8
INCLUDED PARTS	1-9
NIPPLE WRENCH.....	1-9
VALVE JOINT.....	1-9
SET PIN (tool for YPVS).....	1-9
IMPORTANT INFORMATION	1-10
PREPARATION FOR REMOVAL AND DISASSEMBLY.....	1-10
REPLACEMENT PARTS.....	1-10
INSTRUMENT AND CONTROL FUNCTIONS	1-11
ENGINE STOP SWITCH.....	1-11
SHIFT PEDAL	1-11
KICKSTARTER LEVER.....	1-11
FRONT BRAKE LEVER	1-11
REAR BRAKE PEDAL.....	1-11
FUEL COCK	1-11
STARTER KNOB (CHOKE)	1-12
SIDESTAND	1-12
STARTING AND BREAK-IN	1-13
FUEL AND ENGINE MIXING OIL	1-13
STARTING A COLD ENGINE	1-13
STARTING A WARM ENGINE.....	1-13
BREAK-IN PROCEDURES	1-13
MAINTENANCE AFTER BREAK-IN	1-15
MAJOR MAINTENANCE.....	1-15
AIR FILTER MAINTENANCE	1-15
TORQUE-CHECK POINTS	1-16
MOTORCYCLE CARE AND STORAGE	1-18
CARE.....	1-18
STORAGE	1-19

EAM20168

SAFETY INFORMATION

Be sure to read this manual carefully and completely in order to operate the machine safely and correctly prior to riding the Yamaha machine, and take care to maintain it properly and operate it safely.

EAM30401

FOR SAFETY, BE SURE TO OBEY THE FOLLOWING:

Be a Responsible Owner

As the vehicle's owner, you are responsible for the safe and proper operation of your motorcycle.

Motorcycles are single-track vehicles.

Their safe use and operation are dependent upon the use of proper riding techniques as well as the expertise of the operator. Every operator should know the following requirements before riding this motorcycle.

He or she should:

1. Obtain thorough instructions from a competent source on all aspects of motorcycle operation.
2. Observe the warnings and maintenance requirements in this manual.
3. Obtain qualified training in safe and proper riding techniques.
4. Obtain professional technical service as indicated in this manual and/or when made necessary by mechanical conditions.
5. Never operate a motorcycle without proper training or instruction. Take a training course. Beginners should receive training from a certified instructor. Contact an authorized motorcycle dealer to find out about the training courses nearest you.

Safe Riding

Perform the pre-operation checks each time you use the vehicle to make sure it is in safe operating condition. Failure to inspect or maintain the vehicle properly increases the possibility of an accident or equipment damage. Refer to "PRE-OPERATION INSPECTION AND MAINTENANCE" on page 3-4 for a list of pre-operation checks.

1. This motorcycle is designed for off-road use only, therefore, it is illegal to operate it on public streets, roads, or highways, even a dirt or gravel one. Off-road use on public lands may be illegal. Please check local regulations before riding.
2. This motorcycle is designed to carry the oper-

ator only. No passengers.

3. The failure of motorists to detect and recognize motorcycles in traffic is the predominant cause of automobile/motorcycle accidents. Many accidents have been caused by an automobile driver who did not see the motorcycle. Making yourself conspicuous appears to be very effective in reducing the chance of this type of accident.

Therefore:

- Wear a brightly colored jacket.
 - Use extra caution when you are approaching and passing through intersections, since intersections are the most likely places for motorcycle accidents to occur.
 - Ride where other motorists can see you. Avoid riding in another motorist's blind spot.
 - Never maintain a motorcycle without proper knowledge. Contact an authorized motorcycle dealer to inform you on basic motorcycle maintenance. Certain maintenance can only be carried out by certified staff.
4. Many accidents involve inexperienced operators.
 - Make sure that you are qualified and that you only lend your motorcycle to other qualified operators.
 - Know your skills and limits. Staying within your limits may help you to avoid an accident.
 - We recommend that you practice riding your motorcycle until you have become thoroughly familiar with the motorcycle and all of its controls.
 5. Many accidents have been caused by error of the motorcycle operator. A typical error made by the operator is veering wide on a turn due to excessive speed or under cornering (insufficient lean angle for the speed). Never travel faster than warranted by conditions.
 6. Ride cautiously in unfamiliar areas. You may encounter hidden obstacles that could cause an accident.
 7. The posture of the operator is important for proper control. The operator should keep both hands on the handlebar and both feet on the operator footrests during operation to maintain control of the motorcycle.
 8. Never ride under the influence of alcohol or other drugs.
 9. Be sure the transmission is in neutral before starting the engine.

Protective Apparel

The majority of fatalities from motorcycle acci-

dents are the result of head injuries. The use of a safety helmet is the single most critical factor in the prevention or reduction of head injuries.

1. Always wear an approved helmet.
2. Wear a face shield or goggles. Wind in your unprotected eyes could contribute to an impairment of vision that could delay seeing a hazard.
3. The use of a jacket, heavy boots, trousers, gloves, etc., is effective in preventing or reducing abrasions or lacerations.
4. Never wear loose-fitting clothes, otherwise they could catch on the control levers, foot-rests, or wheels and cause injury or an accident.
5. Always wear protective clothing that covers your legs, ankles, and feet. The engine or exhaust system become very hot during or after operation and can cause burns.

Avoid Carbon Monoxide Poisoning

All engine exhaust contains carbon monoxide, a deadly gas. Breathing carbon monoxide can cause headaches, dizziness, drowsiness, nausea, confusion, and eventually death.

Carbon Monoxide is a colorless, odorless, tasteless gas which may be present even if you do not see or smell any engine exhaust. Deadly levels of carbon monoxide can collect rapidly and you can quickly be overcome and unable to save yourself. Also, deadly levels of carbon monoxide can linger for hours or days in enclosed or poorly ventilated areas. If you experience any symptoms of carbon monoxide poisoning, leave the area immediately, get fresh air, and **SEEK MEDICAL TREATMENT**.

1. Do not run engine indoors. Even if you try to ventilate engine exhaust with fans or open windows and doors, carbon monoxide can rapidly reach dangerous levels.
2. Do not run engine in poorly ventilated or partially enclosed areas such as barns, garages, or carports.
3. Do not run engine outdoors where engine exhaust can be drawn into a building through openings such as windows and doors.

Genuine Yamaha Accessories

Choosing accessories for your vehicle is an important decision. Genuine Yamaha accessories, which are available only from a Yamaha dealer, have been designed, tested, and approved by Yamaha for use on your vehicle.

Many companies with no connection to Yamaha manufacture parts and accessories or offer oth-

er modifications for Yamaha vehicles. Yamaha is not in a position to test the products that these aftermarket companies produce. Therefore, Yamaha can neither endorse nor recommend the use of accessories not sold by Yamaha or modifications not specifically recommended by Yamaha, even if sold and installed by a Yamaha dealer.

Aftermarket Parts, Accessories, and Modifications

While you may find aftermarket products similar in design and quality to genuine Yamaha accessories, recognize that some aftermarket accessories or modifications are not suitable because of potential safety hazards to you or others. Installing aftermarket products or having other modifications performed to your vehicle that change any of the vehicle's design or operation characteristics can put you and others at greater risk of serious injury or death. You are responsible for injuries related to changes in the vehicle. Keep the following guidelines in mind, as well as those provided under "Loading" when mounting accessories.

1. Never install accessories that would impair the performance of your motorcycle. Carefully inspect the accessory before using it to make sure that it does not in any way reduce ground clearance or cornering clearance, limit suspension travel, steering travel or control operation.
 - Accessories fitted to the handlebar or the front fork area can create instability due to improper weight distribution. If accessories are added to the handlebar or front fork area, they must be as lightweight as possible and should be kept to a minimum.
 - Bulky or large accessories may seriously affect the stability of the motorcycle. Wind may attempt to lift the motorcycle, or the motorcycle may become unstable in cross winds.
 - Certain accessories can displace the operator from his or her normal riding position. This improper position limits the freedom of movement of the operator and may limit control ability, therefore, such accessories are not recommended.
2. Use caution when adding electrical accessories. If electrical accessories exceed the capacity of the motorcycle's electrical system, an electric failure could result, which could cause a dangerous loss of lights or engine power.

Aftermarket Tires and Rims

The tires and rims that came with your motorcycle were designed to match the performance capabilities and to provide the best combination of handling, braking, and comfort. Other tires, rims, sizes, and combinations may not be appropriate. Refer to “CHECKING THE TIRES” on page 3-22 for tire specifications and more information on replacing your tires.

Transporting the Motorcycle

Be sure to observe following instructions before transporting the motorcycle in another vehicle.

1. Remove all loose items from the motorcycle.
2. Check that the fuel cock (if equipped) is in the “OFF” position and that there are no fuel leaks.
3. Point the front wheel straight ahead on the trailer or in the truck bed, and choke it in a rail to prevent movement.
4. Shift the transmission in gear (for models with a manual transmission).
5. Secure the motorcycle with tie-downs or suitable straps that are attached to solid parts of the motorcycle, such as the frame or upper front fork triple clamp (and not, for example, to rubber-mounted handlebars or turn signals, or parts that could break). Choose the location for the straps carefully so the straps will not rub against painted surfaces during transport.
6. The suspension should be compressed somewhat by the tie-downs, if possible, so that the motorcycle will not bounce excessively during transport.

LOCATION OF IMPORTANT LABELS

EAM20085

LOCATION OF IMPORTANT LABELS

Please read the following important labels carefully before operating this vehicle.

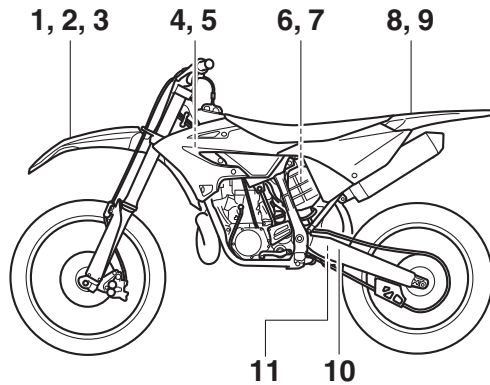

CAN

1

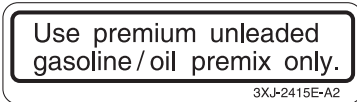

5

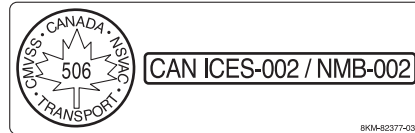

2

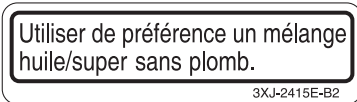

3

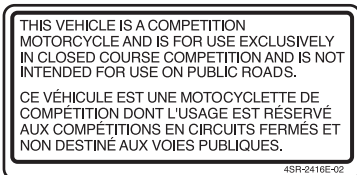

6

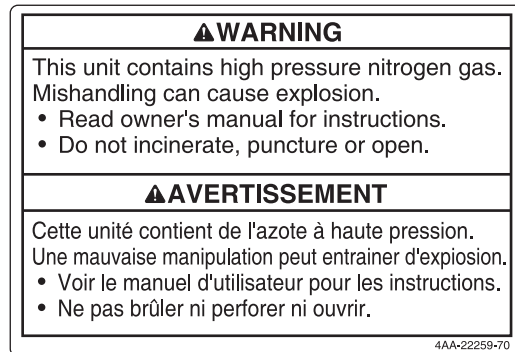

4

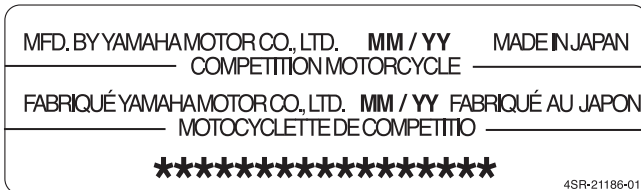

LOCATION OF IMPORTANT LABELS

8

⚠ WARNING

- BEFORE YOU OPERATE THIS VEHICLE, READ THE OWNER'S MANUAL AND ALL LABELS.
- NEVER CARRY A PASSENGER. You increase your risk of losing control if you carry a passenger.
- NEVER OPERATE THIS VEHICLE ON PUBLIC ROADS. You can collide with another vehicle if you operate this vehicle on a public road.
- ALWAYS WEAR AN APPROVED MOTORCYCLE HELMET, eye protection, and protective clothing.
- EXPERIENCED RIDER ONLY.

5PA-2118K-01

9

⚠ AVERTISSEMENT

- LIRE LE MANUEL DU PROPRIETAIRE AINSI QUE TOUTES LES ETIQUETTES AVANT D'UTILISER CE VEHICULE.
- NE JAMAIS TRANSPORTER DE PASSAGER. La conduite avec passager augmente les risques de perte de contrôle.
- NE JAMAIS ROULER SUR DES CHEMINS PUBLICS. Vous pourriez entrer en collision avec un autre véhicule.
- TOUJOURS PORTER UN CASQUE DE MOTOCYCLISTE APPROUVE, des lunettes et des vêtements de protection.
- EXCLUSIVEMENT POUR L'USAGE D'UN CONDUCTEUR EXPERIMENTE.

5PA-2118K-11

10

TIRE INFORMATION

Cold tire normal pressure should be set as follows.
FRONT : 100kPa, {1.00kgf/cm²}, 15psi
REAR : 100kPa, {1.00kgf/cm²}, 15psi

3RV-21668-A1

11

INFORMATION SUR LES PNEUS

La pression des pneus à froid doit normalement être réglée comme suit.
AVANT : 100kPa, {1.00kgf/cm²}, 15psi
ARRIERE : 100kPa, {1.00kgf/cm²}, 15psi

3RV-21668-B1

LOCATION OF IMPORTANT LABELS

AUS, NZL, ZAF

7



10

TIRE INFORMATION
Cold tire normal pressure should be set as follows.
FRONT: 100kPa, {1.00kgf/cm ² }, 15psi
REAR : 100kPa, {1.00kgf/cm ² }, 15psi

3RV-21668-A1

8

⚠ WARNING
<ul style="list-style-type: none">● BEFORE YOU OPERATE THIS VEHICLE, READ THE OWNER'S MANUAL AND ALL LABELS.● NEVER CARRY A PASSENGER. You increase your risk of losing control if you carry a passenger.● NEVER OPERATE THIS VEHICLE ON PUBLIC ROADS. You can collide with another vehicle if you operate this vehicle on a public road.● ALWAYS WEAR AN APPROVED MOTORCYCLE HELMET, eye protection, and protective clothing.● EXPERIENCED RIDER ONLY.

5PA-2118K-01

EAM20086

DESCRIPTION

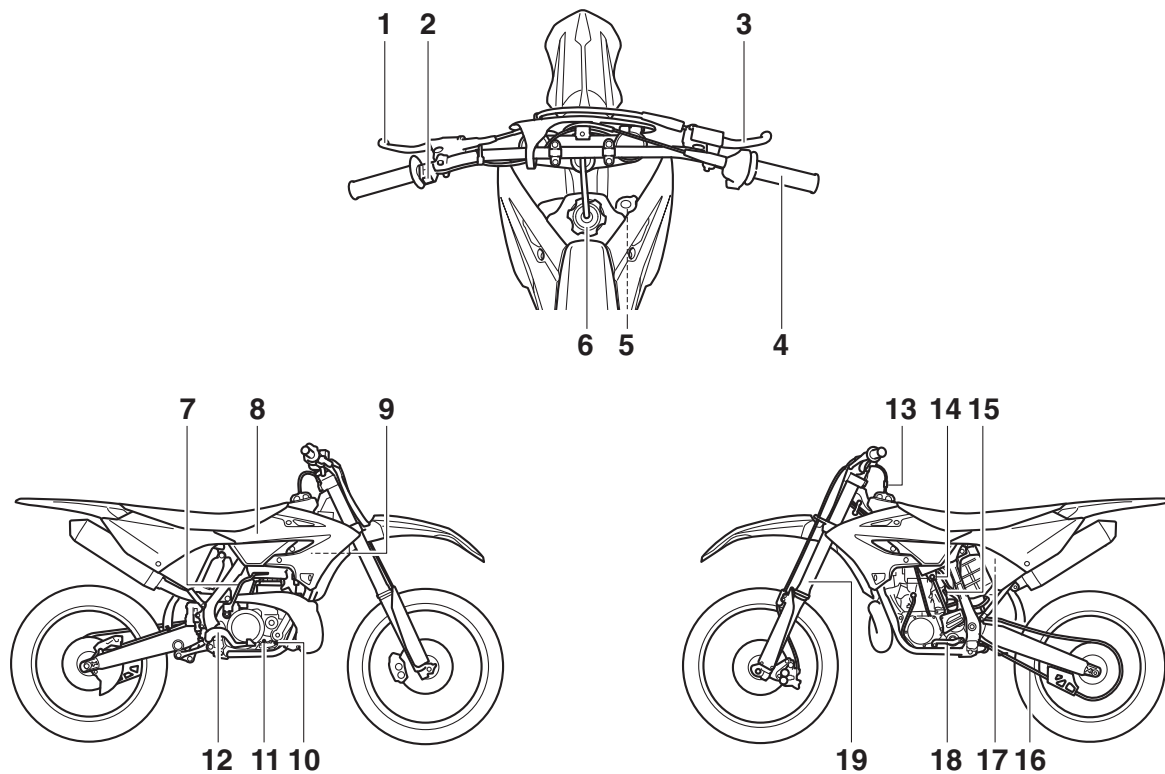

1. Clutch lever
2. Engine stop switch
3. Front brake lever
4. Throttle grip
5. Radiator cap
6. Fuel tank cap
7. Kickstarter lever
8. Fuel tank
9. Radiator
10. Coolant drain bolt

11. Check bolt (Transmission oil level)
12. Rear brake pedal
13. Valve joint
14. Fuel cock
15. Starter knob
16. Drive chain
17. Air filter
18. Shift pedal
19. Front fork

TIP

Designs and specifications of the vehicle are subject to change without notice. Therefore, please note that the descriptions in this manual may be different from those for the vehicle you have purchased.

EAM20087

IDENTIFICATION

There are two significant reasons for knowing the serial number of your vehicle:

1. When ordering parts, you can give the number to your Yamaha dealer for positive identification of the model you own.
2. If your vehicle is stolen, the authorities will need the number to search for and identify your vehicle.

EAM30002

VEHICLE IDENTIFICATION NUMBER

The vehicle identification number "1" is stamped into the right side of the frame.

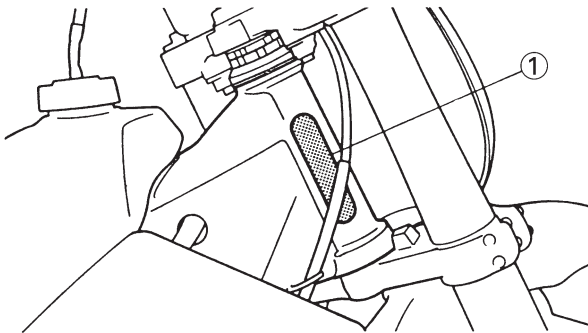

EAM30003

ENGINE SERIAL NUMBER

The engine serial number "1" is stamped into the elevated part of the right-side of the engine.

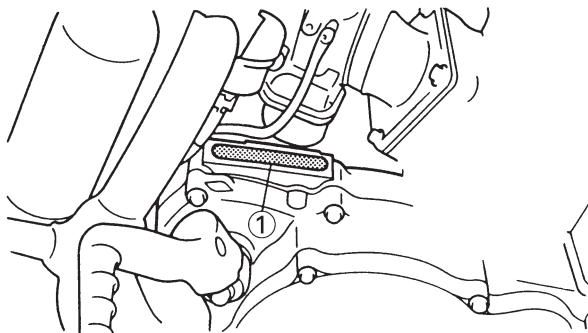

EAM20088

INCLUDED PARTS

EAM30005

NIPPLE WRENCH

The nipple wrench "1" is used to tighten the spoke.

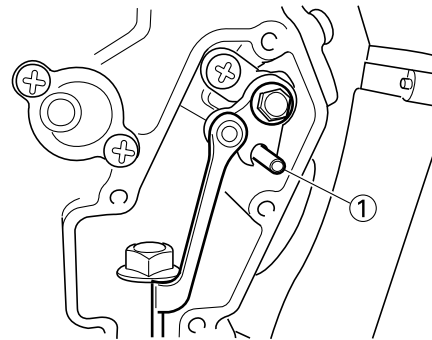
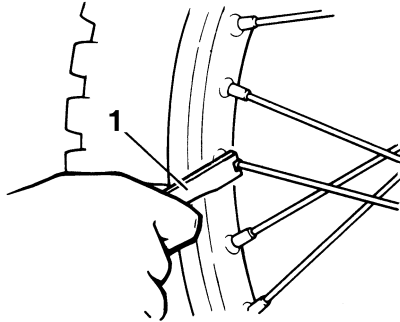

EAM30534

VALVE JOINT

This valve joint "1" prevents fuel from flowing out and is installed to the fuel tank breather hose.

ECA27110

NOTICE

In this installation, make sure the arrow faces the fuel tank and also downward.

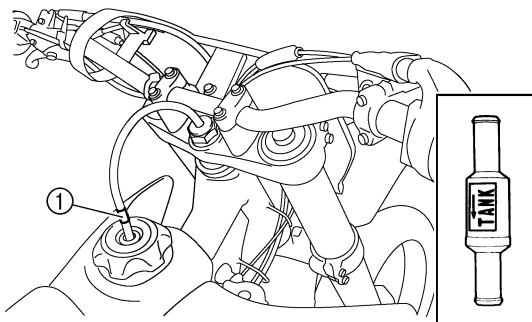

EAM30535

SET PIN (tool for YPVS)

This set pin "1" is used to remove and install the push rod of the engine.

ECA27140

NOTICE

Be sure to use the set pin. If the set pin is not used, the power valve constituent parts will result in damage.

EAM20089

IMPORTANT INFORMATION

EAM30009

PREPARATION FOR REMOVAL AND DISASSEMBLY

1. Before the jobs, completely remove mud, dust, and the like in order to prevent the entry of them into the inside during the jobs. Refer to "CARE" on page 1-18.

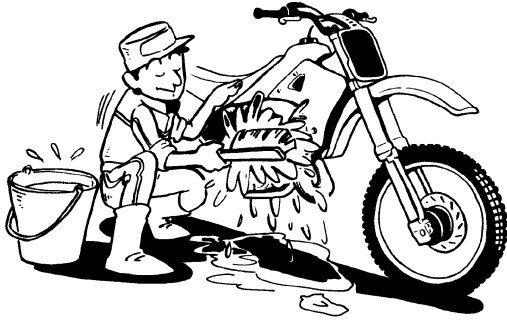

2. During disassembly, check and measure the required parts, and make a record of them so that you may refer to the record when installing them. Moreover, arrange gears, cylinders, pistons, and other parts for each section so as not to confuse or lose them.



3. During disassembly, clean each of the parts, and store them in trays for each section.
4. Flammable. Keep servicing areas away from any source of fire.
5. During servicing, take special care not to receive an injury or a burn on the engine, the exhaust pipe, the silencer, or the like.
6. If coolant is left adhered to the chassis, paint and plating will be damaged. Therefore, rinse it out with water in good time.

EWA18970

WARNING

Coolant is potentially harmful and should be handled with special care.

- If it enters your eyes, wash it away with water enough and then get medical attention
- If it splashes on your skin or clothes, quickly wash it away with water and then with

soapy water.

- If it is swallowed, immediately induce vomiting and get medical attention.

EAM30010

REPLACEMENT PARTS

Make sure that the parts and grease or oil to be used for repair of the vehicle, including periodic replacement parts, are new YAMAHA genuine parts and recommended parts.

Do not use any used parts, because these may not be genuine though they have similar appearances or because the quality may be changed by aging.

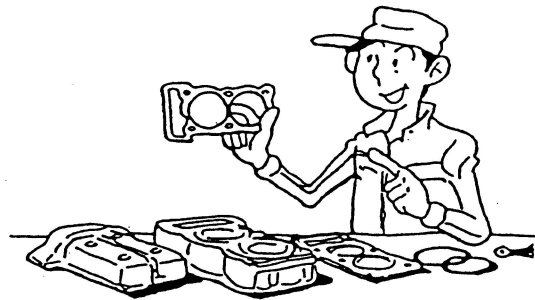

INSTRUMENT AND CONTROL FUNCTIONS

EAM20181

INSTRUMENT AND CONTROL FUNCTIONS

EAM30182

ENGINE STOP SWITCH

The engine stop switch "1" is located on the left handlebar. Continue pushing the engine stop switch till the engine comes to a stop.

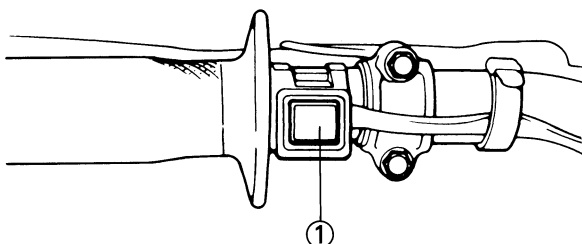

EAM30185

SHIFT PEDAL

The shift pedal "1" has adopted a method of 1 down & 4 ups (press-down & kick-ups). Press it down for N (neutral) to 1st, and kick it up for 2nd to 5th.

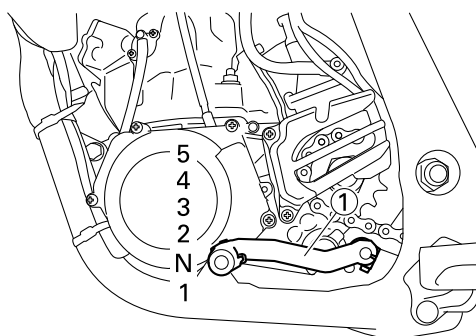

EAM30186

KICKSTARTER LEVER

Rotate the kickstarter lever "1" away from the engine. Push the starter down lightly with your foot until the gears engage, then kick smoothly and forcefully to start the engine. This model has a primary kickstarter lever so the engine can be started in any gear if the clutch is disengaged. In normal practices, however, shift to neutral before starting.

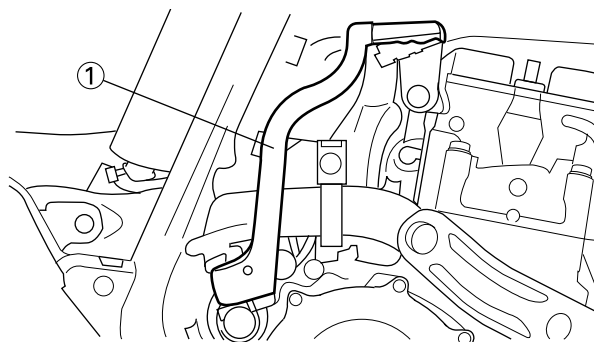

EAM30188

FRONT BRAKE LEVER

The front brake lever "1" is located on the right handlebar. Pull it toward the handlebar to activate the front brake.

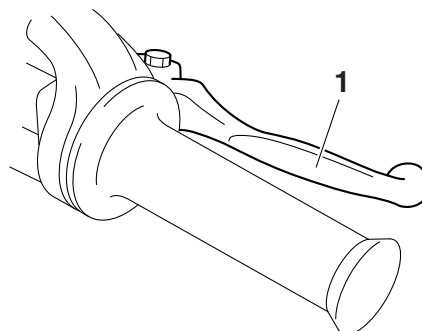

EAM30189

REAR BRAKE PEDAL

The rear brake pedal "1" is in the right of the chassis. Press down on the brake pedal to activate the rear brake.



EAM30619

FUEL COCK

The fuel cock supplies fuel from the tank to carburetor and also filters the fuel. The fuel cock has the three positions:

OFF:

With the lever in this position, fuel will not flow. Always return the lever to this position when the engine is not running.

ON:

With the lever in this position, fuel flows to the carburetor. Normal riding is done with the lever

INSTRUMENT AND CONTROL FUNCTIONS

in this position.

RES:

With the lever in this position fuel flows to the carburetor from the reserve section of the fuel tank after the main supply of the fuel has been depleted. Normal riding is possible with the lever in this position, but it is recommended to add fuel as soon as possible.

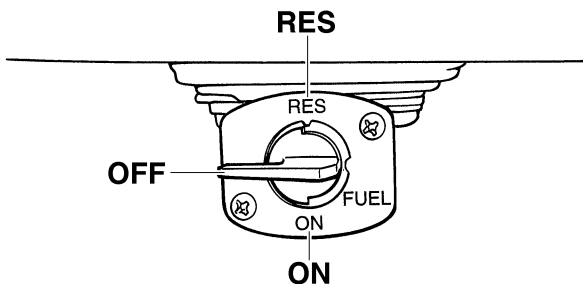
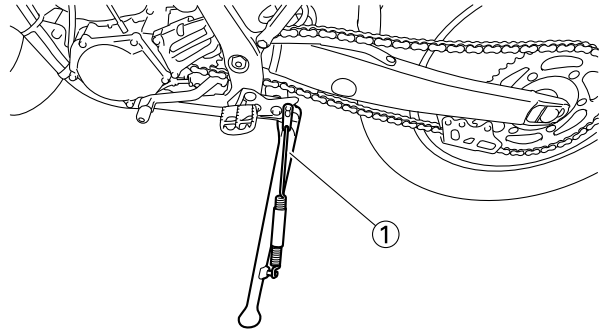

EAM30444

STARTER KNOB (CHOKE)

When cold, the engine requires a richer air-fuel mixture for starting. A separate starter circuit, which is controlled by the starter knob "1", supplies this mixture. Pull the starter knob out to open the circuit for starting. When the engine has warmed up, push it in to close the circuit.

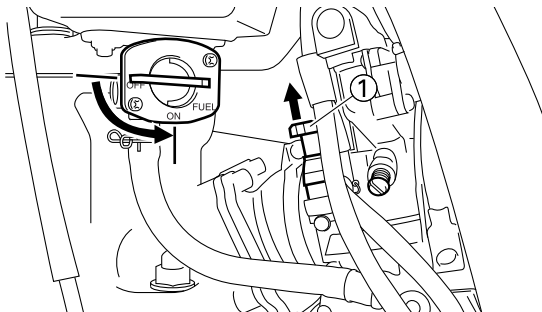

EAM30190

SIDESTAND

This sidestand "1" is used to support only the machine when standing or transporting it.

EWA18980

WARNING

- Never apply additional force to the sidestand.
- Hold up the sidestand before starting out.

EAM20123

STARTING AND BREAK-IN

EAM30538

FUEL AND ENGINE MIXING OIL

Mix oil with the gas at the ratio specified below. Always use fresh, name-brand gasoline, and mix the oil and gas the day of the race. Do not use premix that is more than a few hours old.



Recommended fuel
Premium unleaded gasoline
(E10 acceptable)

TIP

If knocking or pinging occurs, use a different brand of gasoline or higher octane grade.

ECA22260

NOTICE

Never mix two types of oil in the same batch; clotting of the oil could result. If you wish to change oil types, be sure to drain the fuel tank and the carburetor float bowl of old premix prior to filling with the new type.



Fuel tank capacity
7.0 L (1.8 US gal, 1.5 Imp.gal)
Fuel reserve amount
2.0 L (0.53 US gal, 0.44 Imp.gal)



Engine oil
Lubrication system
Premix lubrication
Engine oil
YAMALUBE 2R
Premix ratio
30

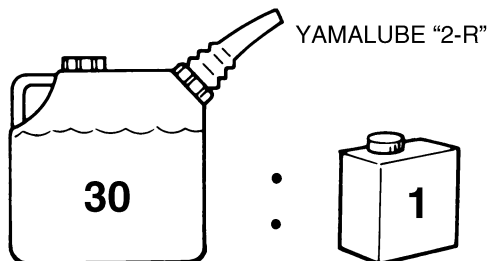

EAM30196

STARTING A COLD ENGINE

1. Shift the transmission into neutral.
2. Turn the fuel cock to "ON" and full open the starter knob (CHOKE).
3. With the throttle completely closed start the engine by kicking the kickstarter forcefully

with firm stroke.

4. Run the engine at idle or slightly higher until it warms up: this usually takes about one or two minutes.
5. The engine is warmed up when it responds normally to the throttle with the starter knob (CHOKE) turned off.

EWA19030

WARNING

Since exhaust gas contains harmful ingredients, do not start or warm it up at an illventilated place or a closed narrow place.

6. To stop the engine, push the engine stop switch.

TIP

Continue pushing the engine stop switch till the engine comes to a full stop.

EAM30197

STARTING A WARM ENGINE

Do not operate the starter knob (CHOKE). Open the throttle slightly and start the engine by kicking the kickstarter forcefully with firm stroke.

EAM30198

BREAK-IN PROCEDURES

A break-in is important so that rotating portion, sliding surfaces, and mounted areas may fit one another, and that the rider may become accustomed to the machine.

ECA25811

NOTICE

Before running, do maintenance on the air filter element.

1. Before starting the engine, fill the fuel tank with a break-in oil-fuel mixture as follows.



Engine oil
YAMALUBE 2R
Premix ratio
15

2. Start and warm up the engine.
3. After warming up the engine, drive it for about 20 minutes at a throttle opening of 1/2 or less.
4. Make a pit stop, and check mounted areas for looseness, oil leaks, or other problems.
5. Then, drive it for about 40 minutes at a throttle opening of 3/4 or less.
6. Make a pit stop again, and thoroughly check mounted areas for looseness, oil leaks, or other problems. Thorough checks and adjustments are required in particular for stretch of cables, free play of the brake, stretch of the

drive chain, looseness of the spoke, and so on.

ECA25821

NOTICE

After a break-in or after each race, always check the points shown in “TORQUE-CHECK POINTS” for tightening torques and retighten them.

Also when the following parts are replaced, a break-in is required.

- **Cylinder and Crankshaft: A break-in is required for about an hour.**
- **Piston, Piston ring, Valve, Camshaft, and Gear: A break-in is required for about 30 minutes at a throttle opening of 1/2 or less.**

Observe the condition of the engine carefully during a break-in.

For checkpoints for a break-in, see “MAINTENANCE AFTER BREAK-IN”. If any problem is found, immediately stop the engine and make a checkup.

EAM20124

MAINTENANCE AFTER BREAK-IN

After a break-in, perform careful maintenance to get ready for the next practice or race.

Refer to “PRE-OPERATION INSPECTION AND MAINTENANCE” on page 3-4.

EAM30199

MAJOR MAINTENANCE

1. For the engine

- Leaks around the engine
Check for pressure leaks from the cylinder head or the cylinder, oil leaks from the crankcase or the case cover, leaks from the coolant system, and other leaks.
- Check that the cylinder, the piston, and the piston ring fit one another, and that contact between the cylinder and the piston are correct.
- Transmission oil change
Drain the oil, and check for dirt and foreign materials such as metal chips. (If any foreign material is mixed, disassemble and check the transmission.)
Pour the specified amount of the recommended oil.
- Carburetor
Disassemble the carburetor and clean the small holes, blowing them with compressed air.
- CDI magneto
Check for looseness in mounted areas of the rotor and the stator.
Check that the connector is not being disconnected.
- Silencer
Check the main body and stay for cracks.
Check for leaks.
- Mounting bolts and nuts
Check for looseness in mounted areas of parts, as well as engine mounting bolts and engine brackets.

2. For the chassis

- Check welds and mounted areas of the frame, the swingarm, the link, the bracket, and so on, for looseness and cracks.
- Wheel(s)
Check the wheel for runout. Check the spoke for looseness.
- Brake(s)
Check the brake disc mounting bolt for looseness.
Check that the reservoir contains the specified amount of brake fluid. Check for leaks.

- Cable
Grease and adjust cables.
- Drive chain
Lubricate the drive chain and adjust its tension.
- Fuel tank
Clean the inside of the fuel tank and the fuel cock. Check for leaks.
- Suspension
Check for oil leaks in the front fork or the rear shock absorber. Check that the mounted conditions are good.
- Sprocket
Check for looseness in the sprocket mounted on the rear wheel.
- Mounting bolts and nuts
Check mounted areas for looseness.

ECA25831

NOTICE

After a break-in or before each race, always check the points shown in “TORQUE-CHECK POINTS” for tightening torques and retighten them.

- Greasing and oiling
Always grease or oil the specified points.

EAM30195

AIR FILTER MAINTENANCE

Apply the Yamaha foam air filter oil or other quality foam air filter oil to the element. (Excess oil in the element may adversely affect engine starting.)

Refer to “CLEANING THE AIR FILTER ELEMENT” on page 3-8.

TORQUE-CHECK POINTS

EAM20125

TORQUE-CHECK POINTS

Frame construction		Combined seat and fuel tank	Fuel tank to frame
			Frame to rear frame
Engine mounting			Frame to engine
			Engine bracket to engine
			Engine bracket to frame
Seat			Seat to frame
Steering		Steering stem to handlebar	Steering stem to frame
			Steering stem to upper bracket
			Upper bracket to handlebar
Suspension	Front	Steering stem to front fork	Front fork to upper bracket
			Front fork to lower bracket
	Rear	Link	Assembly of links
			Link to frame
			Link to rear shock absorber
			Link to swingarm
		Mounting of rear shock absorber	Rear shock absorber and frame
Mounting of swingarm	Tightening of pivot shaft		
Wheel(s)	Mounting of wheel	Front	Tightening of wheel axle
			Tightening of axle holder
			Tightening of spoke nipple
		Rear	Tightening of wheel axle
			Wheel to rear wheel sprocket
			Tightening of spoke nipple
Brake(s)		Front	Brake caliper to front fork
			Brake disc to wheel
			Tightening of union bolt
			Brake master cylinder to handlebar
			Tightening of bleed screw
			Tightening of brake hose holder
		Rear	Brake pedal to frame
			Brake disc to wheel
			Tightening of union bolt
			Brake master cylinder to frame
			Tightening of bleed screw
Tightening of brake hose holder			
Fuel system			Fuel pump to fuel tank
Shift pedal			Shift pedal to shift shaft

TORQUE-CHECK POINTS

Plastic cover	Tightening of front fender
	Tightening of fork leg protector
	Tightening of air scoop
	Left cover to rear frame
	Tightening of side cover
	Tightening of rear fender
	Tightening of mud flap
	Tightening of rear brake disc cover
	Tightening of rear brake caliper cover

TIP

Concerning the tightening torque, refer to "TIGHTENING TORQUES" on page 2-6.

EAM20126

MOTORCYCLE CARE AND STORAGE

EAM30200

CARE

While the open design of a motorcycle reveals the attractiveness of the technology, it also makes it more vulnerable. Rust and corrosion can develop even if high-quality components are used. A rusty exhaust pipe may go unnoticed on a car, however, it detracts from the overall appearance of a motorcycle. Frequent and proper care does not only comply with the terms of the warranty, but it will also keep your motorcycle looking good, extend its life and optimize its performance.

Before cleaning

TIP

Be sure to confirm that the vehicle is completely cooled.

1. Block or cover the following parts with suitable measures.
 - Side cover air intake port “1”
 - Water pump housing hole at the bottom “2”
 - Crankcase cover hole at the bottom (left side) “3”
 - Silencer exhaust port “4”
 - End of each hose

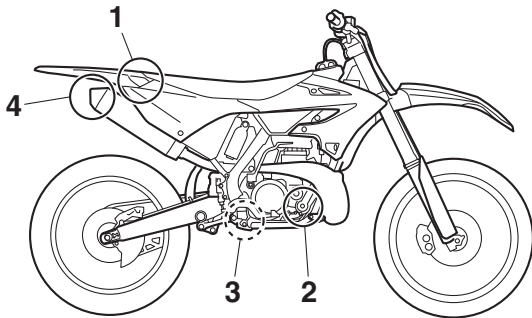

2. Make sure that all caps and covers as well as all electrical couplers and connectors, including the spark plug cap, are tightly installed.
3. Remove extremely stubborn dirt, like oil burnt onto the crankcase, with a degreasing agent and a brush, but never apply such products onto seals, gaskets, sprockets, the drive chain and wheel axles. Always rinse the dirt and degreaser off with water.

Cleaning

ECA26730

NOTICE

- Avoid using strong acidic wheel cleaners, especially on spoked wheels. If such prod-

ucts are used on hard-to-remove dirt, do not leave the cleaner on the affected area any longer than instructed. Also, thoroughly rinse the area off with water, immediately dry it, and then apply a corrosion protection spray.

- Improper cleaning can damage plastic parts (such as cowlings, panels, windshields, headlight lenses, meter lenses, etc.) and the mufflers. Use only a soft, clean cloth or sponge with water to clean plastic. However, if the plastic parts cannot be thoroughly cleaned with water, diluted mild detergent with water may be used. Be sure to rinse off any detergent residue using plenty of water, as it is harmful to plastic parts.
- Do not use any harsh chemical products on plastic parts. Be sure to avoid using cloths or sponges which have been in contact with strong or abrasive cleaning products, solvent or thinner, fuel (gasoline), rust removers or inhibitors, brake fluid, antifreeze or electrolyte.
- For motorcycles equipped with a windshield: Do not use strong cleaners or hard sponges as they will cause dulling or scratching. Some cleaning compounds for plastic may leave scratches on the windshield. Test the product on a small hidden part of the windshield to make sure that it does not leave any marks. If the windshield is scratched, use a quality plastic polishing compound after washing.
- When cleaning using either a high-pressure cleaning machine or a water hose, do not direct the water jet toward the following areas: (Otherwise, it could cause either damage due to the water pressure or malfunction due to water entry.)
 - Wheels or swing arm bearings
 - Fork seals or brake seals
 - Electrical parts, such as couplers, switches, battery, etc.
 - Muffler or hoses
 - Air cleaner intake port
- Do not clean using a water jet with the seat or cover removed.

MOTORCYCLE CARE AND STORAGE

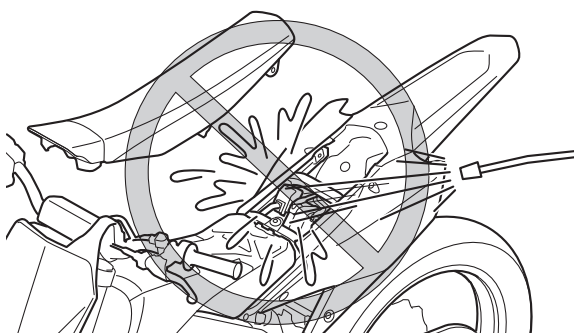

After normal use

Remove dirt with warm water, a mild detergent, and a soft, clean sponge, and then rinse thoroughly with clean water. Use a toothbrush or bottlebrush for hard-to-reach areas. Stubborn dirt and insects will come off more easily if the area is covered with a wet cloth for a few minutes before cleaning.

After riding in the rain, near the sea or on salt-sprayed roads

Since sea salt or salt sprayed on roads during winter are extremely corrosive in combination with water, carry out the following steps after each ride in the rain, near the sea or on salt-sprayed roads.

TIP

Salt sprayed on roads in the winter may remain well into spring.

1. Clean the motorcycle with cold water and a mild detergent, after the engine has cooled down.

NOTICE: Do not use warm water since it increases the corrosive action of the salt.

2. Apply a corrosion protection spray on all metal, including chrome- and nickel-plated, surfaces to prevent corrosion.

After cleaning

1. Dry the motorcycle with a chamois or an absorbing cloth.
2. Immediately dry the drive chain and lubricate it to prevent it from rusting.
3. Use a chrome polish to shine chrome, aluminum and stainless- steel parts, including the exhaust system. (Even the thermally induced discoloring of stainless- steel exhaust systems can be removed through polishing.)
4. To prevent corrosion, it is recommended to apply a corrosion protection spray on all metal, including chrome- and nickel-plated, surfaces.
5. Use spray oil as a universal cleaner to remove any remaining dirt.

6. Touch up minor paint damage caused by stones, etc.
7. Wax all painted surfaces.
8. Let the motorcycle dry completely before storing or covering it.

EWA19050

WARNING

Contaminants on the brakes or tires can cause loss of control.

- **Make sure that there is no oil or wax on the brakes or tires.**
- **If necessary, clean the brake discs and brake linings with a regular brake disc cleaner or acetone, and wash the tires with warm water and a mild detergent. Before riding at higher speeds, test the motorcycle's braking performance and cornering behavior.**

ECA24240

NOTICE

- **Apply spray oil and wax sparingly and make sure to wipe off any excess.**
- **Never apply oil or wax to any rubber and plastic parts, but treat them with a suitable care product.**
- **Avoid using abrasive polishing compounds as they will wear away the paint.**

TIP

- Consult a Yamaha dealer for advice on what products to use.
- Washing, rainy weather or humid climates can cause the headlight lens to fog. Turning the headlight on for a short period of time will help remove the moisture from the lens.

EAM30201

STORAGE

Short-term

Always store your motorcycle in a cool, dry place and, if necessary, protect it against dust with a porous cover. Be sure the engine and the exhaust system are cool before covering the motorcycle.

ECA24250

NOTICE

- **Storing the motorcycle in a poorly ventilated room or covering it with a tarp, while it is still wet, will allow water and humidity to seep in and cause rust.**
- **To prevent corrosion, avoid damp cellars, stables (because of the presence of ammonia) and areas where strong chemicals are**

MOTORCYCLE CARE AND STORAGE

stored.

Long-term

Before storing your motorcycle for several months:

1. Follow all the instructions in "CARE" on page 1-18.
2. Drain the fuel tank, fuel lines, and the carburetor float bowl.
3. Perform the following steps to protect the cylinder, piston rings, etc. from corrosion.
 - a. Remove the spark plug, pour a tablespoon of motor oil in the spark plug hole, and reinstall the plug. With the engine stop switch pushed in, kick the engine over several times to coat the cylinder walls with oil.
4. Lubricate all control cables and the pivoting points of all levers and pedals as well as of the sidestand.
5. Check and, if necessary, correct the tire air pressure, and then lift the motorcycle so that both of its wheels are off the ground. Alternatively, turn the wheels a little every month in order to prevent the tires from becoming degraded in one spot.
6. Cover the muffler outlet with a plastic bag to prevent moisture from entering it.

TIP

Make any necessary repairs before storing the motorcycle.

MOTORCYCLE CARE AND STORAGE

SPECIFICATIONS

GENERAL SPECIFICATIONS	2-1
ENGINE SPECIFICATIONS	2-2
CHASSIS SPECIFICATIONS	2-4
TIGHTENING TORQUES	2-6
GENERAL TIGHTENING TORQUE SPECIFICATIONS.....	2-6
ENGINE TIGHTENING TORQUES.....	2-7
CHASSIS TIGHTENING TORQUES.....	2-9

GENERAL SPECIFICATIONS

EAM20127

GENERAL SPECIFICATIONS

Model

Model	BRY1 (CAN) BRY3 (AUS, NZL)
-------	-------------------------------

Dimensions

Overall length	2185 mm (86.0 in)
Overall width	825 mm (32.5 in)
Overall height	1290 mm (50.8 in)
Seat height	975 mm (38.4 in)
Wheelbase	1485 mm (58.5 in)
Ground clearance	360 mm (14.17 in)

Weight

Curb weight	104 kg (229 lb)
-------------	-----------------

ENGINE SPECIFICATIONS

EAM20128

ENGINE SPECIFICATIONS

Engine

Combustion cycle	2-stroke
Cooling system	Liquid cooled
Induction system	Reed valve
Displacement	249 cm ³
Number of cylinders	Single cylinder
Bore × stroke	66.4 × 72.0 mm (2.61 × 2.83 in)
Compression ratio	7.9–9.4 : 1
Starting system	Kickstarter

Fuel

Recommended fuel	Premium unleaded gasoline (E10 acceptable)
Fuel tank capacity	7.0 L (1.8 US gal, 1.5 Imp.gal)
Fuel reserve amount	2.0 L (0.53 US gal, 0.44 Imp.gal)

Engine oil

Recommended brand	YAMALUBE
Lubrication system	Premix lubrication
Engine oil	YAMALUBE 2R
Premix ratio	30

Transmission oil

Type	Motor oil SAE 10W-40 type SG or higher
Quantity (disassembled)	0.80 L (0.85 US qt, 0.70 Imp.qt)
Quantity	0.75 L (0.79 US qt, 0.66 Imp.qt)

Cooling system

Coolant quantity	
Radiator (including all routes)	1.20 L (1.27 US qt, 1.06 Imp.qt)

Spark plug(s)

Manufacturer/model	NGK/BR8EG
Spark plug gap	0.5–0.6 mm (0.020–0.024 in)

Clutch

Clutch type	Wet, multiple-disc
Clutch lever free play	7.0–12.0 mm (0.28–0.47 in)
Friction plate 1 thickness	2.92–3.08 mm (0.115–0.121 in)
Wear limit	2.82 mm (0.111 in)
Plate quantity	2 pcs
Friction plate 2 thickness	2.90–3.10 mm (0.114–0.122 in)
Wear limit	2.80 mm (0.110 in)
Plate quantity	6 pcs
Clutch plate thickness	1.50–1.70 mm (0.059–0.067 in)
Plate quantity	7 pcs
Warping limit	0.20 mm (0.008 in)
Clutch spring free length	44.00 mm (1.73 in)
Clutch spring free length limit	41.80 mm (1.65 in)
Push rod bending limit	0.30 mm (0.012 in)

Drivetrain

Primary reduction ratio	3.000 (63/21)
Transmission type	Constant mesh 5-speed

ENGINE SPECIFICATIONS

Gear ratio	
1st	1.929 (27/14)
2nd	1.533 (23/15)
3rd	1.313 (21/16)
4th	1.050 (21/20)
5th	0.840 (21/25)
Secondary reduction ratio	3.571 (50/14)
Final drive	Chain

Air filter

Air filter element	Wet element
Air filter oil grade	Yamaha foam air filter oil or other quality foam air filter oil

Carburetor

Type × quantity	PWK38 × 1
ID mark	BRY1 00
Main jet	#178
Main air jet	#200
Jet needle	NYHW-2
Needle jet	2.9(#6)
Cutaway	#7
Pilot outlet	0.8
Pilot jet	#52
Bypass 1	1.5
Air screw turns out	1-1/8
Valve seat size	3.8
Starter jet 1	#85
Power Jet	#55
Float height	6.5 mm (0.26 in)
Throttle grip free play	3.0–5.0 mm (0.12–0.20 in)

CHASSIS SPECIFICATIONS

EAM20129

CHASSIS SPECIFICATIONS

Chassis

Caster angle	27.7 °
Trail	122 mm (4.8 in)

Front wheel

Wheel type	Spoke wheel
Rim size	21 x 1.60

Rear wheel

Wheel type	Spoke wheel
Rim size	18 x 2.15

Front tire

Type	With tube
Size	80/100-21 51M
Manufacturer/model	DUNLOP/MX33F

Rear tire

Type	With tube
Size	110/100-18 64M
Manufacturer/model	DUNLOP/MX33

Tire air pressure (measured on cold tires)

Front	100 kPa (1.00 kgf/cm ² , 15 psi)
Rear	100 kPa (1.00 kgf/cm ² , 15 psi)

Front brake

Type	Hydraulic single disc brake
Brake pad lining thickness limit	1.0 mm (0.04 in)
Specified brake fluid	DOT 4

Rear brake

Type	Hydraulic single disc brake
Brake pad lining thickness limit	1.0 mm (0.04 in)
Specified brake fluid	DOT 4

Front suspension

Type	Telescopic fork
Spring	Coil spring
Shock absorber	Hydraulic damper
Wheel travel	300 mm (11.8 in)
Fork spring free length limit	492.0 mm (19.37 in)
Inner tube bending limit	0.2 mm (0.01 in)
Recommended oil	Yamaha Suspension Oil S1
Quantity (left)	480.0 cm ³ (16.23 US oz, 16.93 Imp.oz)
Quantity (right)	480.0 cm ³ (16.23 US oz, 16.93 Imp.oz)
Rebound damping	
Adjusting system	Mechanical adjustable type
Unit for adjustment	Click
Adjustment value from the start position (Soft)	20
Adjustment value from the start position (STD)	9
Adjustment value from the start position (Hard)	0

CHASSIS SPECIFICATIONS

Compression damping	
Adjusting system	Mechanical adjustable type
Unit for compression damping adjustment	Click
Adjustment value from the start position (Soft)	20
Adjustment value from the start position (STD)	10
Adjustment value from the start position (Hard)	0

Rear suspension

Type	Swingarm (link suspension)
Spring	Coil spring
Shock absorber	Gas-hydraulic damper
Wheel travel	315 mm (12.4 in)
Spring preload	
Adjusting system	Mechanical adjustable type
Adjustment value (Soft)	1.5 mm (0.06 in)
Adjustment value (STD)	8.0 mm (0.31 in)
Adjustment value (Hard)	18.5 mm (0.73 in)
Rebound damping	
Adjusting system	Mechanical adjustable type
Unit for adjustment	Click
Adjustment value from the start position (Soft)	20
Adjustment value from the start position (STD)	9
Adjustment value from the start position (Hard)	0
Compression damping	
Adjusting system	Mechanical adjustable type
Fast compression damping	
Unit for adjustment	Turn
Adjustment value from the start position (Soft)	2
Adjustment value from the start position (STD)	1
Adjustment value from the start position (Hard)	0
Slow compression damping	
Unit for adjustment	Click
Adjustment value from the start position (Soft)	20
Adjustment value from the start position (STD)	8
Adjustment value from the start position (Hard)	0

Drive chain

Size	520
Chain type	Sealed type
Number of links	114
Drive chain slack (Maintenance Stand)	48.0–58.0 mm (1.89–2.28 in)
15-link length limit	239.3 mm (9.42 in)

EAM20131

TIGHTENING TORQUES

EAM30205

GENERAL TIGHTENING TORQUE SPECIFICATIONS

This chart specifies tightening torques for standard fasteners with a standard ISO thread pitch. Tightening torque specifications for special components or assemblies are provided for each chapter of this manual. To avoid warpage, tighten multi-fastener assemblies in a crisscross pattern and progressive stages until the specified tightening torque is reached. Unless otherwise specified, tightening torque specifications require clean, dry threads. Components should be at room temperature.

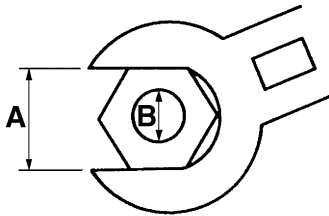

- A. Distance between flats
- B. Outside thread diameter

A (nut)	B (bolt)	General tightening torques		
		N·m	kgf·m	lb·ft
10 mm	6 mm	6	0.6	4.4
12 mm	8 mm	15	1.5	11
14 mm	10 mm	30	3.0	22
17 mm	12 mm	55	5.5	41
19 mm	14 mm	85	8.5	63
22 mm	16 mm	130	13.0	96

TIGHTENING TORQUES

EAM30203











ENGINE TIGHTENING TORQUES

TIP

△ - marked portion shall be checked for torque tightening after break-in or before each race.

Item	Thread size	Q'ty	Tightening torques	Remarks
Spark plug	M14S	1	20 N·m (2.0 kgf·m, 15 lb·ft)	
Cylinder head nut	M8	6	25 N·m (2.5 kgf·m, 18 lb·ft)	
Cylinder head stud bolt	M8	6	13 N·m (1.3 kgf·m, 9.6 lb·ft)	
Cylinder nut	M10	4	42 N·m (4.2 kgf·m, 31 lb·ft)	
Cylinder stud bolt	M10	4	13 N·m (1.3 kgf·m, 9.6 lb·ft)	
Power valve holder 2	M5	2	6 N·m (0.6 kgf·m, 4.4 lb·ft)	
Link rod screw	M5	2	6 N·m (0.6 kgf·m, 4.4 lb·ft)	
Push rod bolt	M5	1	4.5 N·m (0.45 kgf·m, 3.3 lb·ft)	
Thrust plate screw	M5	1	6 N·m (0.6 kgf·m, 4.4 lb·ft)	
Side holder screw	M5	4	4.0 N·m (0.40 kgf·m, 3.0 lb·ft)	
Power valve link lever bolt	M4	1	4.0 N·m (0.40 kgf·m, 3.0 lb·ft)	
Pulley bolt	M4	2	4.0 N·m (0.40 kgf·m, 3.0 lb·ft)	
Power valve cover screw	M5	4	4.0 N·m (0.40 kgf·m, 3.0 lb·ft)	
Governor fork screw	M4	2	5 N·m (0.5 kgf·m, 3.7 lb·ft)	
Power valve housing bolt	M5	4	4.5 N·m (0.45 kgf·m, 3.3 lb·ft)	
Impeller	M8	1	14 N·m (1.4 kgf·m, 10 lb·ft)	
Water pump housing cover bolt	M6	4	10 N·m (1.0 kgf·m, 7.4 lb·ft)	
Coolant drain bolt	M6	1	10 N·m (1.0 kgf·m, 7.4 lb·ft)	
Radiator bolt	M6	4	10 N·m (1.0 kgf·m, 7.4 lb·ft)	
Radiator guard bolt	M6	2	10 N·m (1.0 kgf·m, 7.4 lb·ft)	
Radiator hose clamp	M6	8	1.5 N·m (0.15 kgf·m, 1.1 lb·ft)	
Air filter element	M6	1	2.0 N·m (0.20 kgf·m, 1.5 lb·ft)	
Carburetor joint bolt	M6	5	10 N·m (1.0 kgf·m, 7.4 lb·ft)	
Air filter case bolt	M6	2	8 N·m (0.8 kgf·m, 5.9 lb·ft)	△
Air filter guide clamp	M5	1	3.5 N·m (0.35 kgf·m, 2.6 lb·ft)	
Reed valve screw	M3	4	1.0 N·m (0.10 kgf·m, 0.73 lb·ft)	
Locknut (throttle cable handlebar side)	M8	1	7 N·m (0.7 kgf·m, 5.2 lb·ft)	
Locknut (throttle cable carburetor side)	M6	1	4.0 N·m (0.40 kgf·m, 3.0 lb·ft)	
Exhaust pipe bolt (front)	M6	1	14 N·m (1.4 kgf·m, 10 lb·ft)	△
Exhaust pipe bolt (rear)	M6	1	12 N·m (1.2 kgf·m, 8.9 lb·ft)	△
Exhaust pipe stay bolt (front)	M8	1	25 N·m (2.5 kgf·m, 18 lb·ft)	△
Exhaust pipe stay bolt (rear)	M6	1	12 N·m (1.2 kgf·m, 8.9 lb·ft)	△

TIGHTENING TORQUES

Item	Thread size	Q'ty	Tightening torques	Remarks
Silencer bolt	M6	2	12 N·m (1.2 kgf·m, 8.9 lb·ft)	
Fiber bolt	M6	4	10 N·m (1.0 kgf·m, 7.4 lb·ft)	
Crankcase bolt	M6	11	14 N·m (1.4 kgf·m, 10 lb·ft)	
Crankcase cover screw (left)	M6	5	5 N·m (0.5 kgf·m, 3.7 lb·ft)	
Drive sprocket cover screw	M6	2	5 N·m (0.5 kgf·m, 3.7 lb·ft)	
Crankcase cover screw (right)	M6	9	10 N·m (1.0 kgf·m, 7.4 lb·ft)	
Bearing plate cover screw (drive axle left)	M6	2	10 N·m (1.0 kgf·m, 7.4 lb·ft)	
Bearing plate cover bolt (main axle right)	M6	2	10 N·m (1.0 kgf·m, 7.4 lb·ft)	
Holder bolt	M6	2	10 N·m (1.0 kgf·m, 7.4 lb·ft)	
Oil drain bolt	M12	1	23 N·m (2.3 kgf·m, 17 lb·ft)	
Oil check bolt	M6	1	10 N·m (1.0 kgf·m, 7.4 lb·ft)	
Neutral switch lead holder bolt	M6	1	10 N·m (1.0 kgf·m, 7.4 lb·ft)	
Kickstarter lever	M8	1	30 N·m (3.0 kgf·m, 22 lb·ft)	
Ratchet wheel stopper bolt	M6	2	10 N·m (1.0 kgf·m, 7.4 lb·ft)	
Clutch cover bolt	M6	6	10 N·m (1.0 kgf·m, 7.4 lb·ft)	
Primary drive gear bolt	M10	1	55 N·m (5.5 kgf·m, 41 lb·ft)	
Clutch boss nut	M20	1	75 N·m (7.5 kgf·m, 55 lb·ft)	Use a Lock washer.
Clutch spring bolt	M6	6	10 N·m (1.0 kgf·m, 7.4 lb·ft)	
Locknut (clutch cable side)	M6	1	4.3 N·m (0.43 kgf·m, 3.2 lb·ft)	
Push lever shaft bolt	M5	1	6 N·m (0.6 kgf·m, 4.4 lb·ft)	
Drive sprocket nut	M20	1	75 N·m (7.5 kgf·m, 55 lb·ft)	Use a Lock washer.
Shift guide bolt	M6	2	10 N·m (1.0 kgf·m, 7.4 lb·ft)	
Stopper lever bolt	M6	1	10 N·m (1.0 kgf·m, 7.4 lb·ft)	
Tension spring (shift shaft) stopper bolt	M8	1	22 N·m (2.2 kgf·m, 16 lb·ft)	
Segment bolt	M8	1	30 N·m (3.0 kgf·m, 22 lb·ft)	
Bearing plate cover screw (shift cam right)	M6	2	10 N·m (1.0 kgf·m, 7.4 lb·ft)	
Shift pedal bolt	M6	1	12 N·m (1.2 kgf·m, 8.9 lb·ft)	
Stator coil screw	M6	3	7 N·m (0.7 kgf·m, 5.2 lb·ft)	
CDI magneto rotor nut	M12	1	56 N·m (5.6 kgf·m, 41 lb·ft)	
Ignition coil bolt	M6	2	7 N·m (0.7 kgf·m, 5.2 lb·ft)	
Neutral switch screw	M5	2	4.0 N·m (0.40 kgf·m, 3.0 lb·ft)	

TIGHTENING TORQUES

EAM30204





CHASSIS TIGHTENING TORQUES

TIP

△ - marked portion shall be checked for torque tightening after break-in or before each race.

Item	Thread size	Q'ty	Tightening torques	Remarks
Upper bracket pinch bolt	M8	4	21 N·m (2.1 kgf·m, 15 lb·ft)	△
Lower bracket pinch bolt	M8	4	21 N·m (2.1 kgf·m, 15 lb·ft)	△
Steering stem nut	M24	1	145 N·m (14.5 kgf·m, 107 lb·ft)	△
Upper handlebar holder bolt	M8	4	28 N·m (2.8 kgf·m, 21 lb·ft)	△
Lower handlebar holder nut	M12	2	40 N·m (4.0 kgf·m, 30 lb·ft)	△
Steering ring nut	M28	1	Refer to TIP.	△
Damper assembly (front fork)	M51	2	30 N·m (3.0 kgf·m, 22 lb·ft)	
Inner tube and adjuster	M22	2	55 N·m (5.5 kgf·m, 41 lb·ft)	
Base valve (front fork)	M42	2	28 N·m (2.8 kgf·m, 21 lb·ft)	
Adjuster (damper assembly)	M12	2	29 N·m (2.9 kgf·m, 21 lb·ft)	
Bleed screw (front fork)	M5	2	1.3 N·m (0.13 kgf·m, 0.95 lb·ft)	
Front fork protector bolt	M6	6	5 N·m (0.5 kgf·m, 3.7 lb·ft)	△
Front brake hose holder bolt	M6	2	9 N·m (0.9 kgf·m, 6.6 lb·ft)	△
Throttle cable cap screw	M4	2	0.5 N·m (0.05 kgf·m, 0.37 lb·ft)	
Grip cap bolt	M6	2	3.8 N·m (0.38 kgf·m, 2.8 lb·ft)	
Clutch lever nut	M6	1	4.0 N·m (0.40 kgf·m, 3.0 lb·ft)	
Clutch lever holder bolt	M6	2	5 N·m (0.5 kgf·m, 3.7 lb·ft)	
Locknut (clutch lever position)	M5	1	4.8 N·m (0.48 kgf·m, 3.5 lb·ft)	
Engine stop switch screw	M3	1	0.5 N·m (0.05 kgf·m, 0.37 lb·ft)	
Front brake master cylinder holder bolt	M6	2	9 N·m (0.9 kgf·m, 6.6 lb·ft)	△
Front brake master cylinder reservoir cap screw	M4	2	1.5 N·m (0.15 kgf·m, 1.1 lb·ft)	
Front brake lever pivot bolt	M6	1	6 N·m (0.6 kgf·m, 4.4 lb·ft)	
Front brake lever pivot nut	M6	1	6 N·m (0.6 kgf·m, 4.4 lb·ft)	
Locknut (front brake lever position)	M6	1	5 N·m (0.5 kgf·m, 3.7 lb·ft)	
Cable guide screw	M6	1	3.8 N·m (0.38 kgf·m, 2.8 lb·ft)	△
Front brake hose union bolt	M10	2	30 N·m (3.0 kgf·m, 22 lb·ft)	△
Front brake caliper bolt	M8	2	28 N·m (2.8 kgf·m, 21 lb·ft)	△
Brake pad pin plug	M10	2	2.5 N·m (0.25 kgf·m, 1.8 lb·ft)	
Brake pad pin	M10	2	17 N·m (1.7 kgf·m, 13 lb·ft)	△
Brake caliper bleed screw	M8	2	6 N·m (0.6 kgf·m, 4.4 lb·ft)	△
Front wheel axle nut	M16	1	105 N·m (10.5 kgf·m, 77 lb·ft)	△
Front wheel axle pinch bolt	M8	4	21 N·m (2.1 kgf·m, 15 lb·ft)	△

TIGHTENING TORQUES

Item	Thread size	Q'ty	Tightening torques	Remarks
Front brake disc bolt	M6	6	12 N·m (1.2 kgf·m, 8.9 lb·ft)	△/— 
Rear brake disc bolt	M6	6	12 N·m (1.2 kgf·m, 8.9 lb·ft)	△/— 
Footrest bracket bolt	M10	4	55 N·m (5.5 kgf·m, 41 lb·ft)	— 
Rear brake pedal bolt	M8	1	26 N·m (2.6 kgf·m, 19 lb·ft)	△
Rear brake pedal adjusting locknut	M6	1	6 N·m (0.6 kgf·m, 4.4 lb·ft)	
Rear brake master cylinder bolt	M6	2	10 N·m (1.0 kgf·m, 7.4 lb·ft)	△
Rear brake master cylinder reservoir cap bolt	M4	2	1.5 N·m (0.15 kgf·m, 1.1 lb·ft)	
Rear brake hose union bolt	M10	2	30 N·m (3.0 kgf·m, 22 lb·ft)	△
Rear wheel axle nut	M20	1	125 N·m (12.5 kgf·m, 92 lb·ft)	△
Rear wheel sprocket nut	M8	6	42 N·m (4.2 kgf·m, 31 lb·ft)	△
Nipple (spoke)	—	72	2.5 N·m (0.25 kgf·m, 1.8 lb·ft)	△
Rear brake disc cover bolt	M6	2	10 N·m (1.0 kgf·m, 7.4 lb·ft)	△
Rear brake caliper protector bolt	M6	2	7 N·m (0.7 kgf·m, 5.2 lb·ft)	△
Drive chain puller locknut	M8	2	19 N·m (1.9 kgf·m, 14 lb·ft)	
Engine bracket nut (upper side)	M8	2	34 N·m (3.4 kgf·m, 25 lb·ft)	△
Engine bracket nut (lower side)	M10	1	64 N·m (6.4 kgf·m, 47 lb·ft)	△
Engine mounting nut (front side)	M10	1	64 N·m (6.4 kgf·m, 47 lb·ft)	△
Engine mounting nut (lower side)	M10	1	64 N·m (6.4 kgf·m, 47 lb·ft)	△
Pivot shaft nut	M16	1	85 N·m (8.5 kgf·m, 63 lb·ft)	△
Relay arm nut (swingarm side)	M14	1	70 N·m (7.0 kgf·m, 52 lb·ft)	△
Connecting arm nut (relay arm side)	M14	1	80 N·m (8.0 kgf·m, 59 lb·ft)	△
Connecting arm nut (frame side)	M14	1	80 N·m (8.0 kgf·m, 59 lb·ft)	△
Rear shock absorber assembly upper nut	M10	1	56 N·m (5.6 kgf·m, 41 lb·ft)	△
Rear shock absorber assembly lower nut	M10	1	53 N·m (5.3 kgf·m, 39 lb·ft)	△
Rear frame bolt (upper)	M8	1	32 N·m (3.2 kgf·m, 24 lb·ft)	△
Rear frame bolt (lower)	M8	2	29 N·m (2.9 kgf·m, 21 lb·ft)	△
Brake hose holder screw	M5	4	3.5 N·m (0.35 kgf·m, 2.6 lb·ft)	△
Swingarm and patch screw	M4	4	2.0 N·m (0.20 kgf·m, 1.5 lb·ft)	— 
Drive chain tensioner bolt	M8	1	16 N·m (1.6 kgf·m, 12 lb·ft)	
Drive chain tensioner nut	M8	1	16 N·m (1.6 kgf·m, 12 lb·ft)	
Drive chain support bolt	M6	1	7 N·m (0.7 kgf·m, 5.2 lb·ft)	
Drive chain support nut	M6	2	7 N·m (0.7 kgf·m, 5.2 lb·ft)	
Drive chain guide bolt	M5	4	6 N·m (0.6 kgf·m, 4.4 lb·ft)	
Fuel tank bolt (boss)	M10	2	20 N·m (2.0 kgf·m, 15 lb·ft)	△/— 

TIGHTENING TORQUES

Item	Thread size	Q'ty	Tightening torques	Remarks
Fuel tank bolt	M6	2	10 N·m (1.0 kgf·m, 7.4 lb·ft)	△
Fuel cock screw	M6	2	4.0 N·m (0.40 kgf·m, 3.0 lb·ft)	△
Fuel tank screw (seat set side)	M6	1	7 N·m (0.7 kgf·m, 5.2 lb·ft)	
Fuel tank bracket bolt	M6	4	7 N·m (0.7 kgf·m, 5.2 lb·ft)	
Seat bolt	M6	1	11 N·m (1.1 kgf·m, 8.1 lb·ft)	△
Side cover bolt (front side)	M6	2	7 N·m (0.7 kgf·m, 5.2 lb·ft)	△
Side cover bolt (rear side)	M6	2	9 N·m (0.9 kgf·m, 6.6 lb·ft)	△
Air scoop bolt (fuel tank)	M6	4	7 N·m (0.7 kgf·m, 5.2 lb·ft)	△
Air scoop bolt (radiator guard)	M6	2	7 N·m (0.7 kgf·m, 5.2 lb·ft)	△
Front fender bolt	M6	4	10 N·m (1.0 kgf·m, 7.4 lb·ft)	△
Rear fender bolt (front side)	M6	2	7 N·m (0.7 kgf·m, 5.2 lb·ft)	△
Rear fender bolt (rear side)	M6	2	12 N·m (1.2 kgf·m, 8.9 lb·ft)	△/— 
Screw (mud flap)	—	2	1.3 N·m (0.13 kgf·m, 0.95 lb·ft)	△
Number plate bolt	M6	1	7 N·m (0.7 kgf·m, 5.2 lb·ft)	△
Sidestand bolt	M10	1	25 N·m (2.5 kgf·m, 18 lb·ft)	

TIP

Steering ring nut

1. First, tighten the steering ring nut approximately 38 N·m (3.8 kgf·m, 28 lb·ft) by using the steering nut wrench, then loosen the steering ring nut one turn.
2. Retighten the steering ring nut 7 N·m (0.7 kgf·m, 5.2 lb·ft).

PERIODIC CHECKS AND ADJUSTMENTS

MAINTENANCE INTERVALS	3-1
MAINTENANCE INTERVALS	3-1
PRE-OPERATION INSPECTION AND MAINTENANCE	3-4
GENERAL INSPECTION AND MAINTENANCE.....	3-4
ENGINE	3-5
ADJUSTING THE PILOT AIR SCREW	3-5
CHECKING THE ENGINE IDLING SPEED	3-5
CHECKING THE THROTTLE GRIP.....	3-5
CHECKING THE SPARK PLUG	3-5
CHECKING THE TRANSMISSION OIL LEVEL.....	3-6
CHANGING THE TRANSMISSION OIL.....	3-6
ADJUSTING THE CLUTCH LEVER FREE PLAY	3-7
ADJUSTING THE CLUTCH LEVER POSITION	3-8
CLEANING THE AIR FILTER ELEMENT.....	3-8
CHECKING THE CARBURETOR JOINT.....	3-9
CHECKING THE CARBURETOR HOSES.....	3-9
CHECKING THE EXHAUST SYSTEM.....	3-9
CHECKING THE COOLANT LEVEL.....	3-10
CHECKING THE COOLING SYSTEM.....	3-11
CHANGING THE COOLANT.....	3-11
CHASSIS	3-13
ADJUSTING THE FRONT DISC BRAKE.....	3-13
ADJUSTING THE REAR DISC BRAKE	3-13
CHECKING THE BRAKE FLUID LEVEL.....	3-14
CHECKING THE FRONT BRAKE PADS.....	3-14
CHECKING THE REAR BRAKE PADS	3-14
CHECKING THE FRONT BRAKE HOSE.....	3-14
CHECKING THE REAR BRAKE HOSE	3-15
CHECKING THE BRAKE OPERATION	3-15
BLEEDING THE HYDRAULIC BRAKE SYSTEM	3-15
DRIVE CHAIN SLACK.....	3-16
LUBRICATING THE DRIVE CHAIN	3-17
CHECKING AND ADJUSTING THE STEERING HEAD	3-17
LUBRICATING THE STEERING HEAD.....	3-18
CHECKING THE FRONT FORK LEGS	3-18
ADJUSTING THE FRONT FORK LEGS	3-19
CHECKING THE REAR SHOCK ABSORBER ASSEMBLY	3-20
ADJUSTING THE REAR SHOCK ABSORBER ASSEMBLY.....	3-20
CHECKING THE SWINGARM OPERATION	3-22
LUBRICATING THE SWINGARM PIVOT	3-22
CHECKING THE TIRES.....	3-22
CHECKING AND TIGHTENING THE SPOKES.....	3-23
CHECKING THE WHEELS	3-23
CHECKING THE CHASSIS FASTENERS.....	3-23
CHECKING AND LUBRICATING THE CABLES	3-23

LUBRICATING THE BRAKE LEVER	3-24
LUBRICATING THE CLUTCH LEVER.....	3-24
LUBRICATING THE PEDAL	3-24
CHECKING THE SIDESTAND.....	3-24
LUBRICATING THE SIDESTAND.....	3-24

MAINTENANCE INTERVALS

EAM20157

MAINTENANCE INTERVALS

EAM30369

MAINTENANCE INTERVALS

ECA25871

NOTICE

- After a break-in or before each race, always check the points shown in “TORQUE-CHECK POINTS” for tightening torques and retighten them.
- Periodic inspection is essential in making full use of the machine performance. The life of parts varies significantly according to the environment in which the machine runs (e.g., rain, dirt, etc.). Therefore, earlier inspection is required by reference to the list below.

TIP

Items marked with an asterisk should be performed by a Yamaha dealer as they require special tools, data and technical skills.

No.	Item	Routine	After break-in	Every race (about 2.5 hours)	Every third race (about 7.5 hours)	Every fifth race (about 12.5 hours)	As required
1	* Piston	<ul style="list-style-type: none"> • Check piston for carbon deposits and cracks or damage. • Clean. 	√	√			
		<ul style="list-style-type: none"> • Replace. 				√	√
2	* Piston rings	<ul style="list-style-type: none"> • Check piston ring end gap and rings for damage. 	√	√			
		<ul style="list-style-type: none"> • Replace. 			√		√
3	* Piston pin and small end bearing	<ul style="list-style-type: none"> • Check piston pin and small end bearing for damage. 		√			
		<ul style="list-style-type: none"> • Replace. 					√
4	* Cylinder head	<ul style="list-style-type: none"> • Check cylinder head for carbon deposits. • Clean. 	√	√			
		<ul style="list-style-type: none"> • Check cylinder head gasket for damage. • Tighten cylinder head nuts if necessary. 	√	√			
		<ul style="list-style-type: none"> • Replace cylinder head gasket. 					√
5	* Cylinder	<ul style="list-style-type: none"> • Check cylinder for score marks or wear. • Clean. 	√	√			
		<ul style="list-style-type: none"> • Replace. 					√
6	* YPVS	<ul style="list-style-type: none"> • Check YPVS for carbon deposits and cracks or damage. 	√	√			
		<ul style="list-style-type: none"> • Clean. 	√	√			
7	* Clutch	<ul style="list-style-type: none"> • Check clutch housing, friction plates, clutch plates and clutch springs for wear or damage. • Adjust. 	√	√			
		<ul style="list-style-type: none"> • Replace. 					√
8	* Transmission	<ul style="list-style-type: none"> • Change the transmission oil. 	√			√	
		<ul style="list-style-type: none"> • Check transmission for damage. 					√
		<ul style="list-style-type: none"> • Replace bearings. 					√
9	* Shift forks, guide bars, shift cam	<ul style="list-style-type: none"> • Check all parts for wear and damage. • Replace if necessary. 					√

MAINTENANCE INTERVALS

No.	Item	Routine	After break-in	Every race (about 2.5 hours)	Every third race (about 7.5 hours)	Every fifth race (about 12.5 hours)	As required
10	* Rotor nut (flywheel magneto)	<ul style="list-style-type: none"> Tighten. 	√			√	
11	* Kickstarter system	<ul style="list-style-type: none"> Check idle gear for damage. Replace if necessary. 					√
12	* Exhaust system	<ul style="list-style-type: none"> Check exhaust pipe and muffler for carbon deposits. 	√	√			
		<ul style="list-style-type: none"> Clean. 				√	
13	* Crankshaft	<ul style="list-style-type: none"> Check crankshaft for carbon deposits and damage. 				√	√
		<ul style="list-style-type: none"> Clean. 				√	√
14	* Carburetor	<ul style="list-style-type: none"> Check carburetor settings and for obstructions. 	√	√			
		<ul style="list-style-type: none"> Adjust and clean. 	√	√			
15	Spark plug	<ul style="list-style-type: none"> Check condition. Clean and regap. 	√	√			
		<ul style="list-style-type: none"> Replace. 					√
16	* Drive chain	<ul style="list-style-type: none"> Check chain slack, alignment and condition. Adjust and thoroughly lubricate chain with Yamaha chain and cable lube or equivalent. 	√	√			
		<ul style="list-style-type: none"> Replace. 					√
17	* Cooling system	<ul style="list-style-type: none"> Check coolant level and for leakage. 	√	√			
		<ul style="list-style-type: none"> Check hoses for cracks or damage. 		√			
		<ul style="list-style-type: none"> Check radiator cap spring operation. 					√
		<ul style="list-style-type: none"> Change coolant. 	Every 2 years				√
18	* Chassis fasteners	<ul style="list-style-type: none"> Check all chassis fitting and fasteners. Correct or tighten if necessary. 	√	√			
19	Air filter element	<ul style="list-style-type: none"> Clean. 	√	√			
		<ul style="list-style-type: none"> Replace. 					√
20	* Frame	<ul style="list-style-type: none"> Clean and check for damage. 	√	√			
21	* Fuel line	<ul style="list-style-type: none"> Clean and check for leakage. 	√		√		
22	* Brakes	<ul style="list-style-type: none"> Adjust lever position and pedal position. Lubricate pivot points. Check brake disk surface. Check fluid level and for leakage. Tighten brake disk bolts, caliper bolts, master cylinder bolts and union bolts. 	√	√			
		<ul style="list-style-type: none"> Replace brake pads. 					√
		<ul style="list-style-type: none"> Replace brake fluid. 	Every year				√

MAINTENANCE INTERVALS

No.	Item	Routine	After break-in	Every race (about 2.5 hours)	Every third race (about 7.5 hours)	Every fifth race (about 12.5 hours)	As required
23	* Front fork	<ul style="list-style-type: none"> • Check operation and for oil leakage. • Adjust if necessary. • Clean dust seal and lubricate with lithium-soap-based grease. 	√	√			
		<ul style="list-style-type: none"> • Replace fork oil. 	√			√	
		<ul style="list-style-type: none"> • Replace oil seals. 					√
		<ul style="list-style-type: none"> • Replace protector seal. 					√
24	* Shock absorber assembly	<ul style="list-style-type: none"> • Check operation and adjust. • Tighten if necessary. 	√	√			
		<ul style="list-style-type: none"> • Lubricate with lithium-soap-based grease. 			√		√ (After washing the motorcycle or riding in the rain)
25	* Drive chain roller and support guide	<ul style="list-style-type: none"> • Check for wear or damage. • Replace if necessary. 					√
26	* Rear suspension	<ul style="list-style-type: none"> • Check operation and tighten if necessary. 	√	√			
		<ul style="list-style-type: none"> • Lubricate with molybdenum disulfide grease. 	√	√			
27	* Swingarm pivot bearings	<ul style="list-style-type: none"> • Check bearing assemblies for looseness. • Lubricate with molybdenum disulfide grease. 	√	√			
28	Sidestand	<ul style="list-style-type: none"> • Lubricate with lithium-soap-based grease. 					√
29	* Steering head	<ul style="list-style-type: none"> • Check operation, free play, and tighten if necessary. 	√	√			
		<ul style="list-style-type: none"> • Clean and lubricate with lithium-soap-based grease. 				√	
		<ul style="list-style-type: none"> • Replace bearings. 					√
30	* Tires and wheels	<ul style="list-style-type: none"> • Check tire air pressure, wheel runout, spokes for looseness, and tires for wear. 	√	√			
		<ul style="list-style-type: none"> • Tighten sprocket bolts if necessary. 	√	√			
		<ul style="list-style-type: none"> • Check wheel bearings for looseness. 			√		
		<ul style="list-style-type: none"> • Lubricate wheel bearings with lithium-soap-based grease. 			√		
		<ul style="list-style-type: none"> • Replace wheel bearings. 					√
31	* Moving parts and cables	<ul style="list-style-type: none"> • Lubricate. 	√	√			
32	* Throttle grip	<ul style="list-style-type: none"> • Check operation. • Check throttle grip free play, and adjust if necessary. • Lubricate cable and grip housing. 	√	√			

PRE-OPERATION INSPECTION AND MAINTENANCE

EAM20134

PRE-OPERATION INSPECTION AND MAINTENANCE

Before riding for break-in operation, practice or a race, make sure the machine is in good operating condition.

Before using this machine, check the following points.

EAM30209

GENERAL INSPECTION AND MAINTENANCE

Item	Inspect	Page
Coolant	Check that coolant is filled up to the radiator cap. Check the cooling system for leakage.	3-10, 3-11, 3-11
Fuel	Check that a fresh gasoline is filled in the fuel tank. Check the fuel line for leakage.	1-13
Transmission oil	Check that the oil level is correct. Check the crankcase for leakage.	3-6, 3-6
Gear shifter and clutch	Check that gears can be shifted correctly in order and that the clutch operates smoothly.	3-7, 3-8
Throttle grip/Housing	Check that the throttle grip operation and free play are correctly adjusted. Lubricate the throttle grip and housing, if necessary.	3-5, 3-23
Brakes	Check the play of front brake and effect of front and rear brake.	3-13, 3-13, 3-14, 3-14, 3-14, 3-14, 3-15, 3-15
Drive chain	Check drive chain slack and alignment. Check that the drive chain is lubricated properly.	3-16, 4-30, 4-30, 4-31, 4-31, 4-31
Wheels	Check for excessive wear and tire pressure. Check for loose spokes and have no excessive play.	3-22, 3-23, 3-23
Steering	Check that the handlebar can be turned smoothly and have no excessive play.	3-17
Front forks and rear shock absorber	Check that they operate smoothly and there is no oil leakage.	3-18, 3-19, 3-20, 3-20, 3-22
Cables (wires)	Check that the clutch and throttle cables move smoothly. Check that they are not caught when the handlebars are turned or when the front forks travel up and down.	—
Exhaust pipe	Check that the exhaust pipe is tightly mounted and has no cracks.	3-9
Rear wheel sprocket	Check that the rear wheel sprocket tightening bolt is not loose.	4-3, 4-3, 4-3
Lubrication	Check for smooth operation. Lubricate if necessary.	3-23, 3-24, 3-24, 3-24
Bolts and nuts	Check the chassis and engine for loose bolts and nuts.	1-16
Lead connectors	Check that the stator coil assembly, CDI and ignition coil are connected tightly.	—
Settings	Is the machine set suitably for the condition of the racing course and weather or by taking into account the results of test runs before racing? Are inspection and maintenance completely done?	8-10, 8-10, 8-10, 8-11, 8-11, 8-12, 8-12, 8-13, 8-13, 8-15, 8-16

TIP

Perform usual maintenance enough so that, in the race course, a confirmation of that and simple setting adjustments may only be left, in order to get enough time to use effectively.

EAM20135

ENGINE

EAM30607

ADJUSTING THE PILOT AIR SCREW

1. Adjust:

- Pilot air screw "1"

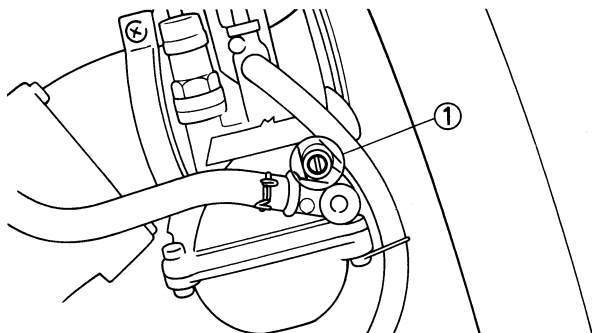

TIP

To optimize the fuel flow at a smaller throttle opening, each vehicle's pilot air screw has been individually set at the factory. Before adjusting the pilot air screw, turn it in fully and count the number of turns. Record this number as the factory-set number of turns out.

- Turn in the pilot air screw until it is lightly seated.
- Turn out the pilot air screw to the factory-set number of turns.



**Air screw turns out
1-1/8**

EAM30412

CHECKING THE ENGINE IDLING SPEED

1. Start the engine and thoroughly warm it up.

2. Adjust:

- Engine idling speed
 - Turn the throttle stop screw "1" until the engine runs at the lowest possible speed.

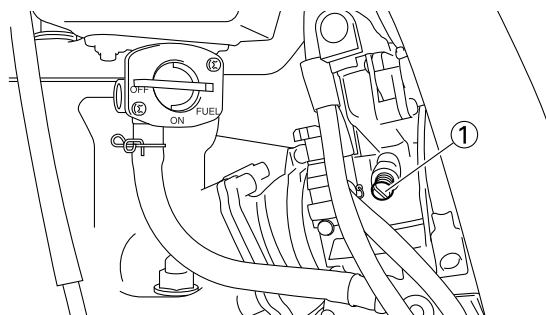

EAM30475

CHECKING THE THROTTLE GRIP

TIP

Prior to adjusting throttle grip free play, the en-

gine idling speed should be adjusted.

1. Check:

- Throttle grip free play "a"
Out of specification → Regulate.



**Throttle grip free play
3.0–5.0 mm (0.12–0.20 in)**

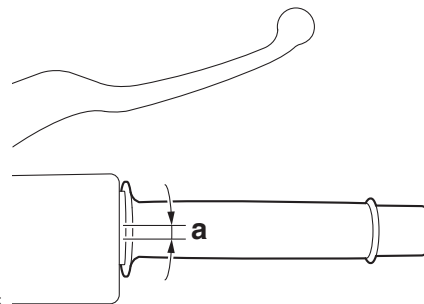

G088895

2. Adjust:

- Throttle grip free play
 - Slide the adjuster cover.
 - Loosen the locknut "1".
 - Turn the adjuster "2" until the specified free play is obtained.
 - Tighten the locknut.

EWA18470

! WARNING

After adjusting the throttle grip free play, start the engine and turn the handlebar to the right and to the left to ensure that this does not cause the engine idling speed to change.

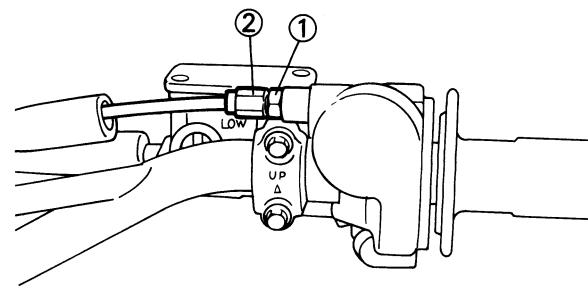

EAM30254

CHECKING THE SPARK PLUG

1. Disconnect:

- Spark plug cap

2. Remove:

- Spark plug

ECA13330

NOTICE

Before removing the spark plug, blow away any dirt accumulated in the spark plug well with compressed air to prevent it from falling

into the cylinder.

3. Check:

- Spark plug type
Incorrect → Change.



Manufacturer/model
NGK/BR8EG

4. Check:

- Electrode “1”
Damage/wear → Replace the spark plug.
- Insulator “2”
Abnormal color → Replace the spark plug.
Normal color is medium-to-light tan.

5. Clean:

- Spark plug
(with a spark plug cleaner or wire brush)

6. Measure:

- Spark plug gap “a”
(with a wire thickness gauge)
Out of specification → Regap.



Spark plug gap
0.5–0.6 mm (0.020–0.024 in)

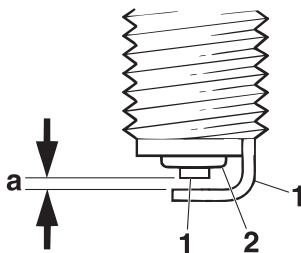

G088879

7. Install:

- Spark plug



Spark plug
20 N·m (2.0 kgf·m, 15 lb·ft)

TIP

Before installing the spark plug, clean the spark plug and gasket surface.

8. Connect:

- Spark plug cap

EAM30539

CHECKING THE TRANSMISSION OIL LEVEL

1. Start the engine, warm it up for several minutes and wait for five minutes.
2. Place the machine on a level place and hold it up on upright position by placing the maintenance stand under the engine.

3. Check:

- Transmission oil level
 - a. Remove the oil check bolt “1”.
 - b. Inspect the oil level.

TIP

Be sure the machine is positioned straight up when inspecting the oil level.

EWA21090



WARNING

Never attempt to remove the oil check bolt just after high speed operation. The heated oil could spout out, causing danger. Wait until the oil cools down.

Oil flows out → Oil level is correct.

Oil does not flow out → Oil level is low.
Add transmission oil until oil flows out.



Type
Motor oil SAE 10W-40 type SG or higher

Quantity (disassembled)
0.80 L (0.85 US qt, 0.70 Imp.qt)

Quantity
0.75 L (0.79 US qt, 0.66 Imp.qt)

- c. Inspect the gasket (oil check bolt), replace if damaged.
- d. Tighten the oil check bolt.



Oil check bolt
10 N·m (1.0 kgf·m, 7.4 lb·ft)

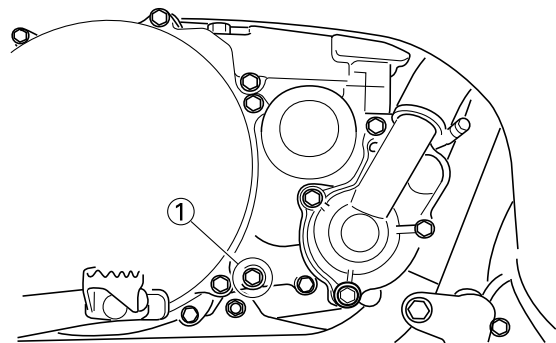

EAM30540

CHANGING THE TRANSMISSION OIL

1. Start the engine and warm it up for several minutes and wait for five minute.
2. Place the machine on a level place and hold it on upright position by placing the maintenance stand under the engine.
3. Place a suitable container under the engine.
4. Remove:
 - Oil drain bolt “1”
 - Oil filler cap “2”

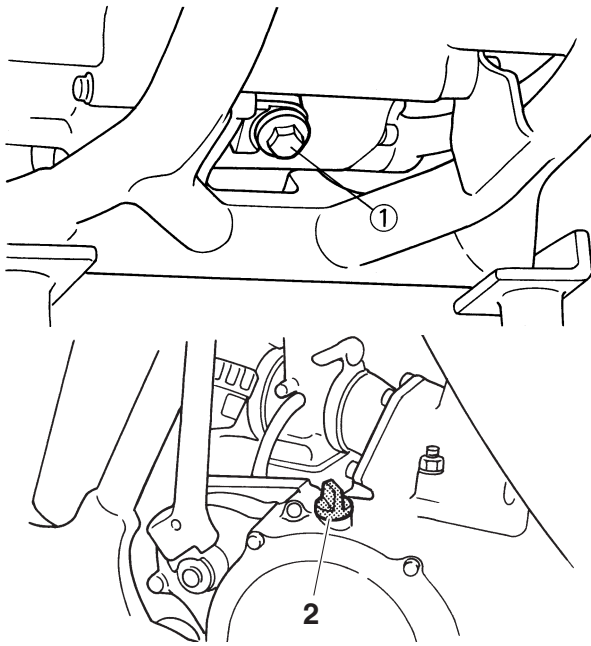

5. Drain:
 - Transmission oil
6. Install:
 - Aluminum washer **New**
 - Oil drain bolt

	Oil drain bolt 23 N·m (2.3 kgf·m, 17 lb·ft)
---	--

7. Fill:
 - Transmission oil

	Type Motor oil SAE 10W-40 type SG or higher Quantity (disassembled) 0.80 L (0.85 US qt, 0.70 Imp.qt) Quantity 0.75 L (0.79 US qt, 0.66 Imp.qt)
---	---

8. Check:
 - Oil leakage
9. Check:
 - Transmission oil level
10. Install:
 - Oil filler cap

EAM30216

ADJUSTING THE CLUTCH LEVER FREE PLAY

1. Check:
 - Clutch lever free play “a”
Out of specification → Regulate.

	Clutch lever free play 7.0–12.0 mm (0.28–0.47 in)
---	--

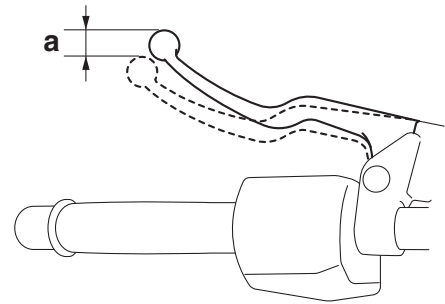

G088887

2. Adjust:
 - Clutch lever free play
Handlebar side
 - a. Turn the adjuster “1” until the specified clutch lever free play is obtained.

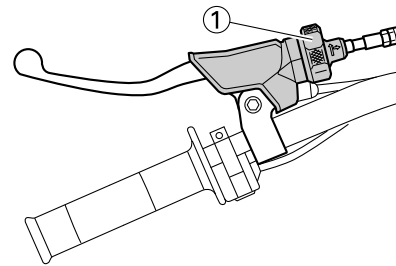

TIP
If the clutch lever free play cannot be obtained on the handlebar side, use the adjuster on the clutch cable side.

Clutch cable side

- a. Slide the clutch cable cover.
- b. Loosen the locknut “1”.
- c. Turn the adjuster “2” until the specified clutch lever free play is obtained.
- d. Tighten the locknut “1”.

	Locknut (clutch cable side) 4.3 N·m (0.43 kgf·m, 3.2 lb·ft)
---	--

- e. Return the clutch cable cover to its original position.

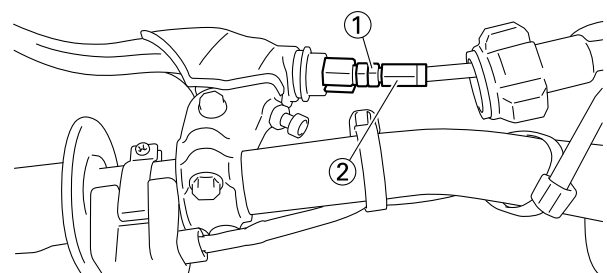

EAM30370

ADJUSTING THE CLUTCH LEVER POSITION

1. Adjust:

- Clutch lever position "a"
Loosen the locknut "1" and use the adjuster "2" to adjust the clutch lever position "a" as desired.

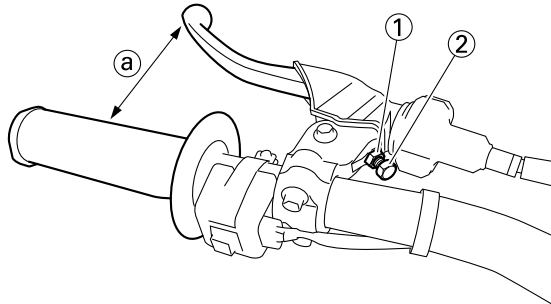

2. Tighten:

- Locknut



Locknut (clutch lever position)
4.8 N·m (0.48 kgf·m, 3.5 lb-ft)

EAM30219

CLEANING THE AIR FILTER ELEMENT

1. Remove:

- Seat

2. Remove:

- Fitting bolt "1"
- Washer "2"
- Air filter element "3"
- Air filter guide "4"

ECA14401

NOTICE

Never operate the engine without the air filter element installed. Unfiltered air will cause rapid wear of engine parts and may damage the engine. Operating the engine without the air filter element will also affect carburetor synchronization, leading to poor engine performance and possible overheating.

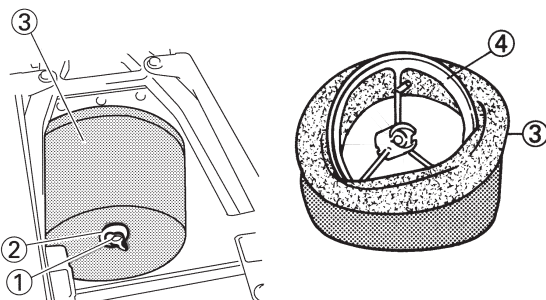

3. Wash:

- Air filter element

- After washing the element with air filter cleaner or kerosene, squeeze and dry it completely.

EWA19110

WARNING

Do not use gasoline or organic (acid/alkaline) volatile oil for washing.

ECA24280

NOTICE

Do not twist the element when squeezing the element.

4. Check:

- Air filter element
Damage → Replace.

5. Apply:

- Yamaha foam air filter oil or other quality foam air filter oil
 - Put the air filter element into a plastic bag and drip the filter oil into the bag.
 - With the element inside the bag, rub it thoroughly so that the element is evenly permeated with the oil.
 - Wrap the element in a clean cloth, rub the element gently, and wipe off any excess oil.

TIP

- The element should be permeated with oil so that it is wet but not dripping.
- When replacing the element, permeate the element in oil by using the same procedure as when cleaning.

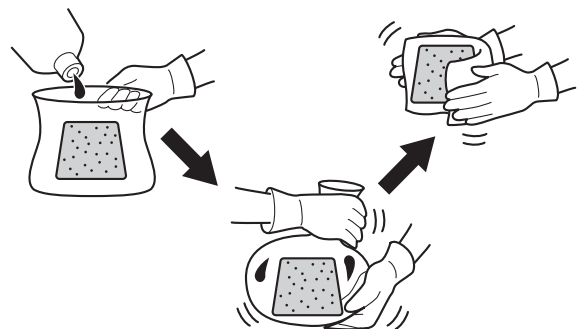

6. Install:

- Air filter guide "1"

TIP

Align the projection "a" on filter guide with the hole "b" in air filter element.

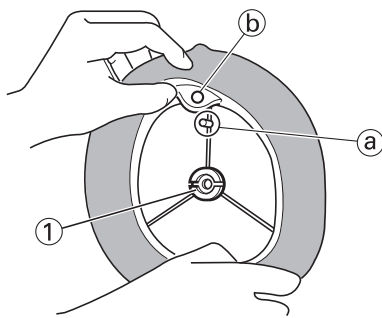

7. Apply:

- Lithium-soap-based grease (on the matching surface “a” on air filter element)

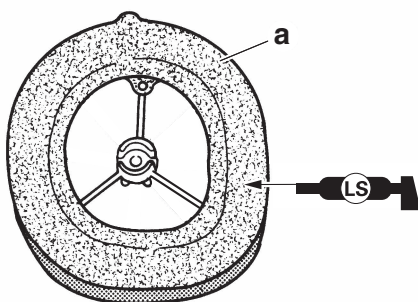

8. Install:

- Air filter element “1”
- Washer
- Fitting bolt

	Fitting bolt 2.0 N·m (0.20 kgf·m, 1.5 lb-ft)
--	---

TIP

Align the projection “a” on filter guide with the hole “b” in air filter case.

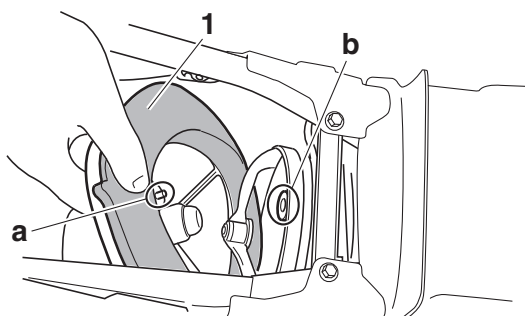

ECA26420

NOTICE

Make sure that the air filter element is properly seated in the air filter case. The engine should never be operated without the air filter element installed, otherwise the piston(s) and/or cylinder(s) may become excessively

worn.

EAM30541

CHECKING THE CARBURETOR JOINT

1. Check:

- Carburetor joint “1”
Cracks/damage → Replace.

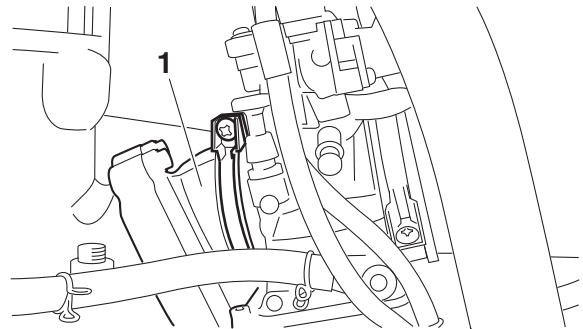

EAM30542

CHECKING THE CARBURETOR HOSES

The following procedure applies to all of the fuel and vacuum hoses.

1. Check:

- Fuel hose
- Carburetor breather hose “1”
- Overflow hose “2”
Cracks/damage → Replace.
Loose connection → Connect properly.

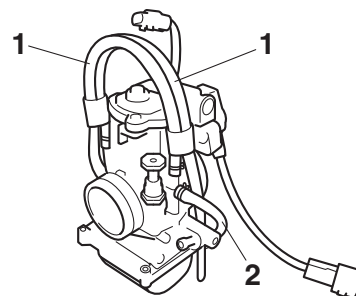

EAM30221

CHECKING THE EXHAUST SYSTEM

1. Remove:

- Exhaust pipe
- Silencer

2. Check:

- Exhaust pipe
Crack/damage → Replace.

3. Check:

- Silencer fiber
Damage → Replace.

4. Replace:

- Silencer fiber
a. Remove the silencer bolts “1”, silencer “2” and fiber bolts “3”.

TIP

Remove the inner pipe while holding the silencer in place with a vise etc.

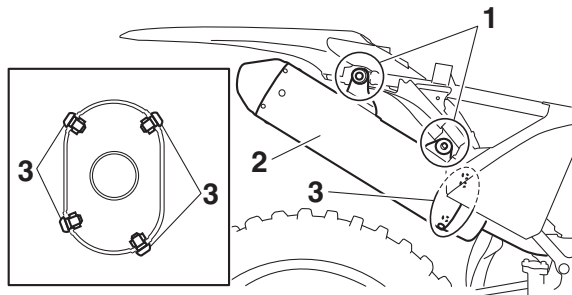

- b. Remove the inner pipe "1".
- c. Replace the fiber "2".
- d. Install the inner pipe.

TIP

Apply heat-resistant sealant to the areas shown, making sure that there are no gaps in the beads of sealant.

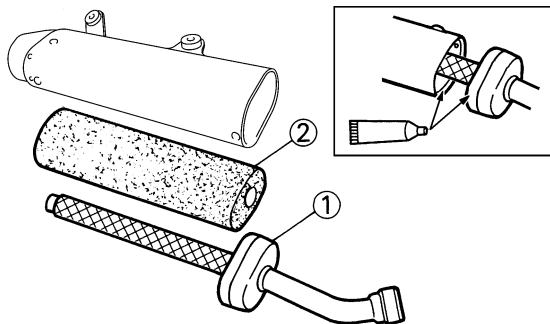

5. Check:
 - Gasket "1"
 - Damage → Replace.

TIP

Install the gaskets with their depressed "a" facing outward.

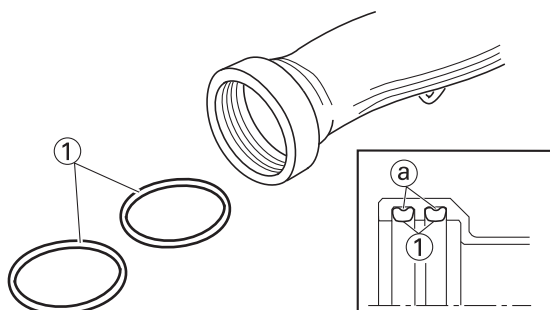

6. Check:
 - Tightening torques



- Fiber bolt "1"**
 10 N·m (1.0 kgf·m, 7.4 lb·ft)
 LOCTITE®
- Silencer bolt "2"**
 12 N·m (1.2 kgf·m, 8.9 lb·ft)
 LOCTITE®
- Side cover bolt (front side)**
 7 N·m (0.7 kgf·m, 5.2 lb·ft)
- Side cover bolt (rear side)**
 9 N·m (0.9 kgf·m, 6.6 lb·ft)

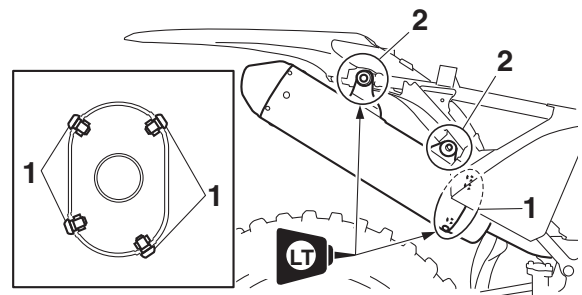

EAM30210

CHECKING THE COOLANT LEVEL

EWA13030

! WARNING

A hot radiator is under pressure. Therefore, do not remove the radiator cap when the engine is hot. Scalding hot fluid and steam may be blown out, which could cause serious injury. When the engine has cooled, open the radiator cap as follows:

Place a thick rag or a towel over the radiator cap and slowly turn the radiator cap counterclockwise toward the detent to allow any residual pressure to escape. When the hissing sound has stopped, press down on the radiator cap and turn it counterclockwise to remove.

1. Stand the vehicle upright on a level surface.
2. Remove:
 - Radiator cap "1"

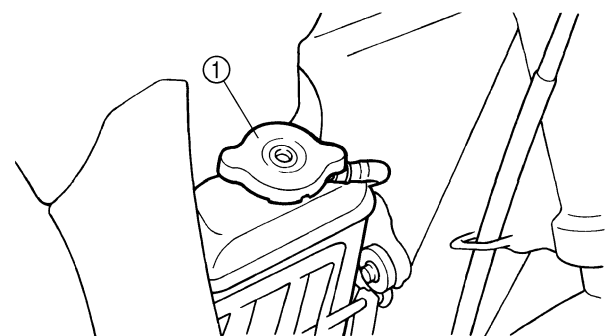

3. Check:
 - Coolant level

Maximum level "a" or below → Add coolant up to the maximum level.

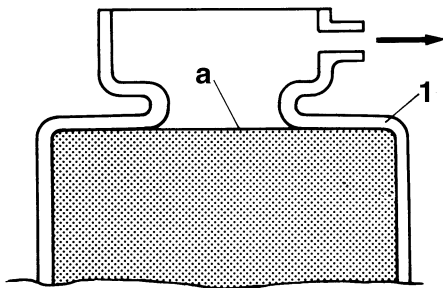

1. Radiator

ECA24260

NOTICE

- Adding water instead of coolant lowers the antifreeze content. If, therefore, water is used instead of coolant, check, and if necessary, adjust the antifreeze concentration.
- Use only distilled water. However, if distilled water is not available, soft water may be used.

4. Start the engine, warm this up for several minutes, and then stop it.

5. Check:
- Coolant level

TIP

Before checking the coolant level, wait a few minutes until the coolant has settled.

EAM30211

CHECKING THE COOLING SYSTEM

1. Remove:
 - Seat
 - Side cover (left/right)
 - Air scoop (left/right)
2. Check:
 - Radiator
 - Radiator hose

Crack/damage → Replace.
3. Install:
 - Air scoop (left/right)
 - Seat
 - Side cover (left/right)

EAM30212

CHANGING THE COOLANT

EWA13030

⚠ WARNING

A hot radiator is under pressure. Therefore, do not remove the radiator cap when the engine is hot. Scalding hot fluid and steam may be blown out, which could cause serious in-

jury. When the engine has cooled, open the radiator cap as follows:

Place a thick rag or a towel over the radiator cap and slowly turn the radiator cap counterclockwise toward the detent to allow any residual pressure to escape. When the hissing sound has stopped, press down on the radiator cap and turn it counterclockwise to remove.

1. Place a container under the engine.
2. Remove:
 - Coolant drain bolt "1"

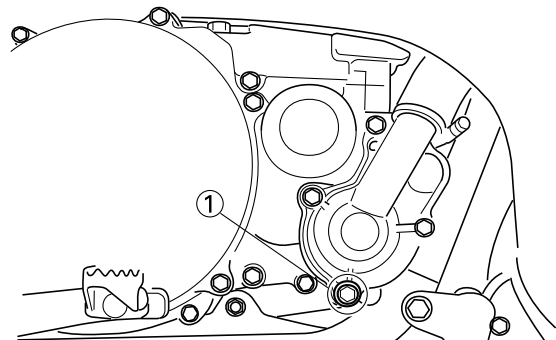

3. Remove:
 - Radiator cap

Slowly loosen the radiator cap to drain coolant.

TIP

When the radiator cap is loosened, coolant will gush out transversely; therefore, bring the container near to the outlet.

4. Thoroughly flush the cooling system with clean tap water.
5. Install:
 - Copper washer **New**
 - Coolant drain bolt

	Coolant drain bolt 10 N·m (1.0 kgf·m, 7.4 lb·ft)
---	---

6. Pour coolant.

	<p>Recommended coolant High quality ethylene glycol anti-freeze containing anti-corrosion for aluminum engine Radiator (including all routes) 1.20 L (1.27 US qt, 1.06 Imp.qt) Coolant mixing ratio 1:1 (Coolant:Water)</p>
---	--

EWA13040

⚠ WARNING

- If coolant splashes in your eyes, thorough-

ly wash them with water and consult a doctor.

- If coolant splashes on your clothes, quickly wash it away with water and then with soap and water.
- If coolant is swallowed, induce vomiting and get immediate medical attention.

ECA13481

NOTICE

- Adding water instead of coolant lowers the antifreeze content of the coolant. If water is used instead of coolant, check, and if necessary, correct the antifreeze concentration of the coolant.
- Use only distilled water. However, if distilled water is not available, soft water may be used.
- If coolant comes into contact with painted surfaces, immediately wash them with water.
- Do not mix different types of antifreeze.

7. Install:

- Radiator cap

8. Start the engine, warm this up for several minutes, stop it, and then wait for it to cool down.

9. Check:

- Coolant level

Refer to "CHECKING THE COOLANT LEVEL" on page 3-10.

EAM20136

CHASSIS

EAM30479

ADJUSTING THE FRONT DISC BRAKE

TIP

There should be no free play at the brake lever end.

1. Check:
 - Brake lever position "a"



Brake lever position
100 mm (3.94 in)
Extent of adjustment
86–105 mm (3.39–4.13 in)

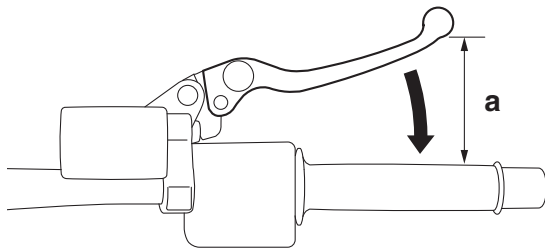

G088889

2. Remove:
 - Brake lever cover
3. Adjust:
 - Brake lever position
 - a. Loosen the locknut "1".
 - b. Turn the adjusting bolt "2" until the specified brake lever position is obtained.

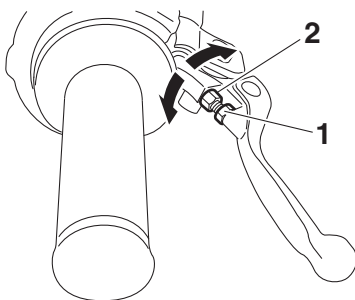

- c. Tighten the locknut.



Locknut (front brake lever position)
5 N·m (0.5 kgf·m, 3.7 lb·ft)

EWA13050

WARNING

A soft or spongy feeling in the brake lever can indicate the presence of air in the brake system. Before the vehicle is operated, the

air must be removed by bleeding the brake system. Air in the brake system will considerably reduce braking performance.

ECA13490

NOTICE

After adjusting the brake lever position, make sure there is no brake drag.

4. Install:
 - Brake lever cover

EAM30480

ADJUSTING THE REAR DISC BRAKE

1. Adjust:
 - Brake pedal position
 - a. Loosen the locknut "1".
 - b. Turn the adjusting nut "2" until the brake pedal is in the correct position.

EWA20710

WARNING

Adjust the pedal height between the maximum "A" and the minimum "B" as shown. (In this adjustment, the bolt "3" end "a" should protrude out of the lower adjusting nut "4" but not be less than 2.0 mm (0.08 in) "b" away from the brake pedal "5").

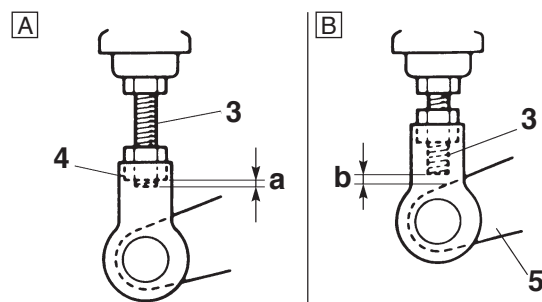
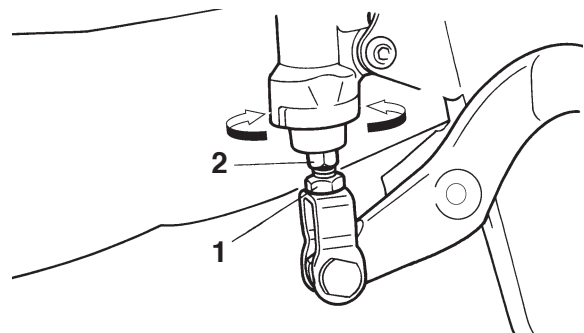

- c. Tighten the locknut to specification.



Rear brake pedal adjusting locknut
6 N·m (0.6 kgf·m, 4.4 lb·ft)

EWA19150

WARNING

A soft or spongy feeling in the brake pedal can indicate the presence of air in the brake system. Before running, bleed the brake system. Air in the brake system will cause braking performance to be reduced.

ECA13510

NOTICE

After adjusting the brake pedal position, make sure there is no brake drag.

EAM30234

CHECKING THE BRAKE FLUID LEVEL

1. Stand the vehicle upright on a level surface.

TIP

In order to ensure a correct reading of the brake fluid level, make sure that the top of the brake fluid reservoir is horizontal.

2. Check:

- Brake fluid level

The minimum level mark "a" or below → Add.



A

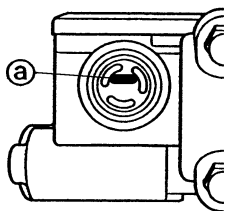

B

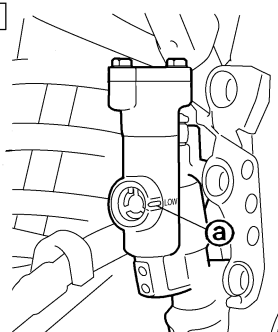

- A. Front brake
B. Rear brake

EWA13090

WARNING

- Use only the designated brake fluid. Other brake fluids may cause the rubber seals to deteriorate, causing leakage and poor brake performance.
- Refill with the same type of brake fluid that is already in the system. Mixing brake fluids may result in a harmful chemical reaction, leading to poor brake performance.
- When refilling, be careful that water does not enter the brake fluid reservoir. Water will significantly lower the boiling point of the brake fluid and could cause vapor lock.

ECA13540

NOTICE

Brake fluid may damage painted surfaces and plastic parts. Therefore, always clean up any spilt brake fluid immediately.

EAM30231

CHECKING THE FRONT BRAKE PADS

The following procedure applies to all of the brake pads.

1. Operate the brake.
2. Check:
 - Front brake pad
Wear indicator grooves "1" almost touch the brake disc → Replace the brake pads as a set.
Refer to "FRONT BRAKE" on page 4-5.

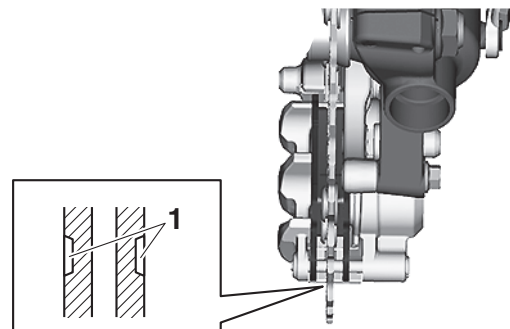

EAM30232

CHECKING THE REAR BRAKE PADS

The following procedure applies to all of the brake pads.

1. Operate the brake.
2. Check:
 - Rear brake pad
Wear indicator grooves "1" almost disappeared → Replace the brake pads as a set.
Refer to "REAR BRAKE" on page 4-7.

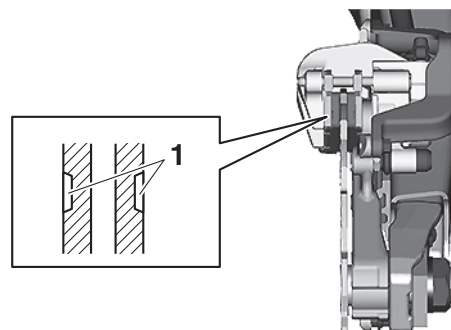

EAM30478

CHECKING THE FRONT BRAKE HOSE

1. Check:
 - Brake hose
Cracks/damage/wear → Replace.

2. Check:
 - Brake hose clamp
Loose connection → Tighten the clamp bolt.
3. Stand the vehicle upright and apply the front brake several times.
4. Check:
 - Brake hose
Brake fluid leaks → Replace the damaged brake hose.

EAM30498

CHECKING THE REAR BRAKE HOSE

1. Check:
 - Brake hose
Cracks/damage/wear → Replace.
2. Check:
 - Brake hose holder
Loose connection → Tighten the holder bolt.
3. Hold the vehicle upright and apply the rear brake several times.
4. Check:
 - Brake hose
Brake fluid leakage → Replace the damaged hose.

EAM30499

CHECKING THE BRAKE OPERATION

1. Check:
 - Brake operation
Brake not working properly → Check the brake system.

TIP

Drive on the dry road, operate the front and rear brakes separately and check to see if the brakes are operating properly.

EAM30477

BLEEDING THE HYDRAULIC BRAKE SYSTEM

EWA19140



WARNING

Bleed the brake system whenever:

- The system is disassembled.
- A brake hose is loosened, disconnected, or replaced.
- The brake fluid level is very low.
- Brake operation is faulty.

1. Remove:
 - Brake master cylinder cap
 - Reservoir diaphragm
 - Reservoir float (front brake)
 - Protector (rear brake)

TIP

- Be careful not to spill any brake fluid or allow

the reservoir to overflow.

- Make sure that there is enough brake fluid before applying the brake. Ignoring this precaution could allow air to enter the brake system, considerably lengthening the bleeding procedure.
- If bleeding is difficult, it may be necessary to let the brake fluid settle for a few hours. Repeat the bleeding procedure when the tiny bubbles in the hose have disappeared.

2. Bleed the brake system.

- a. Fill the reservoir to the proper level with the recommended brake fluid.
- b. Install the reservoir diaphragm.
- c. Connect the plastic hose "1" to the bleed screw "2" securely, and place a container under the end of the plastic hose.

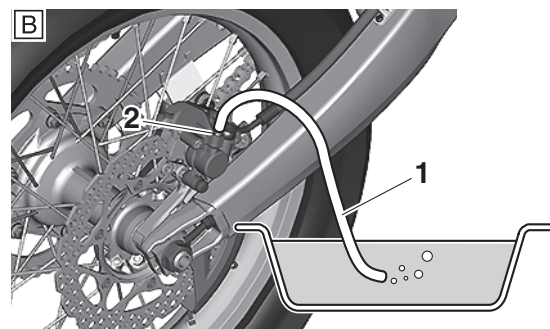
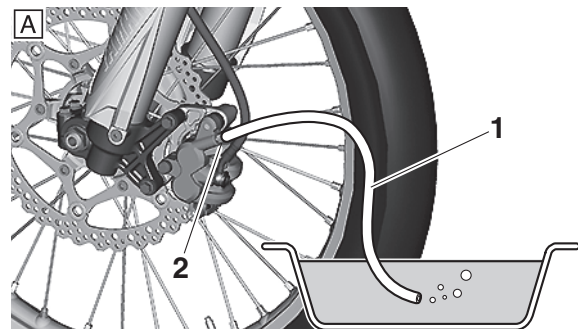

- A. Front
- B. Rear

- d. Slowly apply the brake several times.
- e. Fully pull the brake lever or fully press down the brake pedal and hold it in position.
- f. Loosen the bleed screw.

TIP

Loosening the bleed screw will release the pressure in the brake caliper and cause the brake lever to contact the throttle grip or the brake pedal to fully extend.

- g. Tighten the bleed screw and then release the brake lever or brake pedal.

- h. Repeat steps (d) to (g) until all of the air bubbles have disappeared from the brake fluid in the plastic hose.

TIP

During the procedure, keep adding brake fluid to the reservoir.

ECA24320

NOTICE

- Wipe off any brake fluid on the brake discs, tires, wheels, etc.
- Brake fluid may erode painted surfaces or plastic parts. Always clean up spilled fluid immediately.

- i. Tighten the bleed screw.



Brake caliper bleed screw
6 N·m (0.6 kgf·m, 4.4 lb·ft)

- j. Pour brake fluid to the reservoir up to the specified level.
Refer to “CHECKING THE BRAKE FLUID LEVEL” on page 3-14.

EWA13110

WARNING

After bleeding the hydraulic brake system, check the brake operation.

EAM30481

DRIVE CHAIN SLACK

ECA13550

NOTICE

A drive chain that is too tight will overload the engine and other vital parts, and one that is too loose can skip and damage the swing-arm or cause an accident. Therefore, keep the drive chain slack within the specified limits.

Checking the drive chain slack

1. Use a maintenance stand to raise the rear wheel off the ground.

EWA13120

WARNING

Securely support the vehicle so that there is no danger of it falling over.

2. Shift the transmission into the neutral position.
3. Pull the drive chain up above the drive chain guide installation bolt with a force of about 50 N (5.0 kgf, 37 lbf).
4. Check:
 - Drive chain slack “a”
Out of specification → Regulate.

TIP

Measure drive chain slack between the drive chain guide and the bottom of the chain as shown.

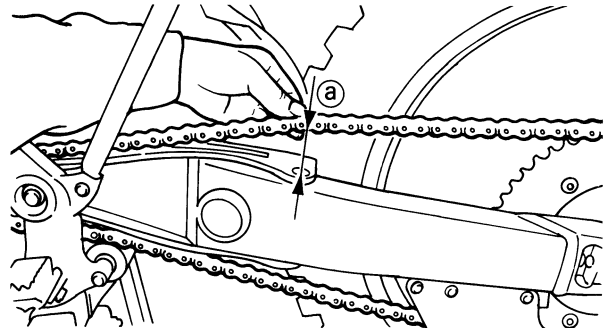

Drive chain slack (Maintenance Stand)
48.0–58.0 mm (1.89–2.28 in)

Adjusting the drive chain slack

EWA13120

WARNING

Securely support the vehicle so that there is no danger of it falling over.

1. Adjust:
 - Drive chain slack
 - a. Loosen the wheel axle nut “1”.
 - b. Loosen both locknuts “2”.
 - c. Turn the adjusting bolt “3” until the specified drive chain slack is obtained.

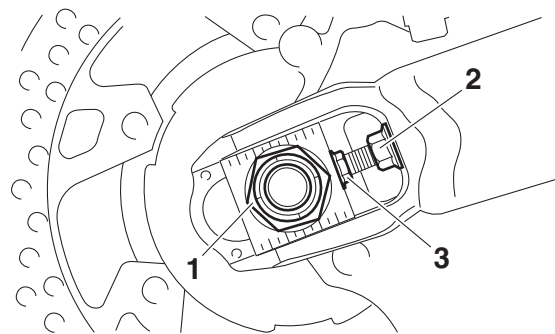

TIP

- To maintain the proper wheel alignment, adjust both sides evenly.
- Push the rear wheel forward to make sure that there is no clearance between the swingarm end plates and the ends of the swingarm.

- d. Tighten the wheel axle nut.



Rear wheel axle nut
125 N·m (12.5 kgf·m, 92 lb·ft)

- e. Tighten the drive chain puller locknut.



Drive chain puller locknut
19 N·m (1.9 kgf·m, 14 lb·ft)

EAM30251

LUBRICATING THE DRIVE CHAIN

The drive chain consists of many interacting parts. If the drive chain is not maintained properly, it will wear out quickly. Therefore, the drive chain should be serviced, especially when the vehicle is used in dusty areas.

This vehicle has a drive chain with small rubber O-rings between each side plate. Steam cleaning, high-pressure washing, certain solvents, and the use of a coarse brush can damage these O-rings. Therefore, use only kerosene to clean the drive chain. Wipe the drive chain dry and thoroughly lubricate it with engine oil or chain lubricant that is suitable for O-ring chains. Do not use any other lubricants on the drive chain since they may contain solvents that could damage the O-rings.



Recommended lubricant
Chain lubricant suitable for O-
ring chains

EAM30247

CHECKING AND ADJUSTING THE STEERING HEAD

1. Use a maintenance stand to raise the front wheel off the ground.

EWA13120



WARNING

Securely support the vehicle so that there is no danger of it falling over.

2. Check:

- Steering head
 Grasp the bottom of the front fork legs and gently rock the front fork.
 Blinding/looseness → Adjust the steering head.

3. Remove:

- Handlebar
- Upper bracket

4. Adjust:

- Steering head
 - a. Remove the washer "1".

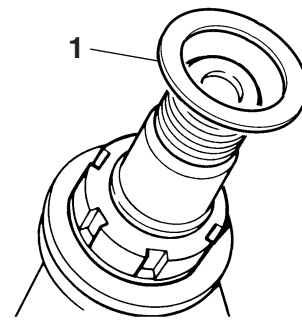

b. After loosening the ring nut "2" with a steering nut wrench "3", tighten it to the specified torque.

TIP

- Set the torque wrench at a right angle to the steering nut wrench.
- Move the steering to the left and right a couple of times to check that it moves smoothly.

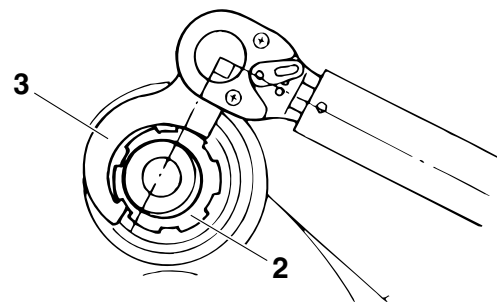

Steering nut wrench
90890-01403
Exhaust flange nut wrench
YU-A9472



Steering ring nut (initial tightening torque)
38 N·m (3.8 kgf·m, 28 lb·ft)

c. Turn the front fork to the right and left a few times, and make sure that the steering rotates smoothly. If it does not turn smoothly, remove the lower bracket and check the upper and lower bearings.

Refer to "STEERING HEAD" on page 4-25.

d. Loosen the ring nut fully turn and then tighten it to specification with a steering nut wrench.

EWA21110



WARNING

Do not overtighten the steering ring nut.



Steering ring nut (final tightening torque)
7 N·m (0.7 kgf·m, 5.2 lb·ft)

- e. Check the steering head for looseness or binding by turning the front fork all the way in both directions. If any binding is felt, remove the lower bracket and check the upper and lower bearings. Refer to “STEERING HEAD” on page 4-25.
- f. Install the washer “1”.

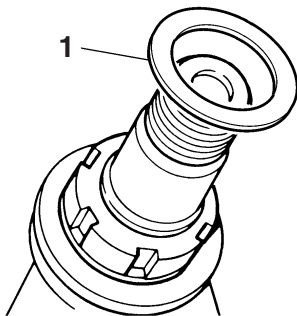

5. Install:
 - Upper bracket
 - Handlebar
 Refer to “HANDLEBAR” on page 4-9.

EAM30502

LUBRICATING THE STEERING HEAD

1. Lubricate:
 - Upper bearing
 - Lower bearing
 - Bearing race



Recommended lubricant
Lithium-soap-based grease

EAM30338

CHECKING THE FRONT FORK LEGS

1. Stand the vehicle upright on a level surface.

EWA13120

WARNING

Securely support the vehicle so that there is no danger of it falling over.

2. Check:
 - Inner tube
Damage/scratches → Replace.
 - Front fork leg
Oil leaks between inner tube and outer tube → Replace the oil seal.
3. Hold the vehicle upright and apply the front brake.

4. Check:
 - Front fork operation
Push down hard on the handlebar several times and check if the front fork rebounds smoothly.
Unsmooth operation → Correct or replace.
Refer to “FRONT FORK” on page 4-14.

TIP
 If any damage is found or the front fork does not operate smoothly, have a Yamaha dealer check or repair it.

5. Check:
 - Protector guide “1”
Out of specification → Replace.

TIP
 The protector guide reaches the limit of its use when it is worn down to the same height “a” as of the outer tube circumference.

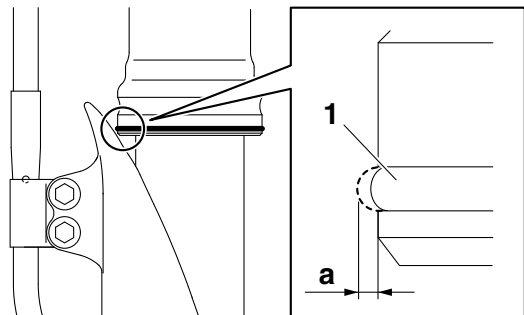

6. Remove:
 - Protector
 - Dust seal “1”

ECA24330

NOTICE

Be careful not to damage the dust seal and the inner tube by a driver.

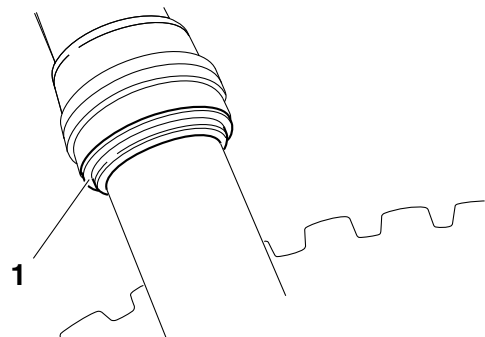

7. Clean:
 - Dust seal “a”
 - Scraper “b”
 - Oil seal “c”

TIP
 • Clean the dust seal, scraper and oil seal after

every run.

- Apply lithium-soap-based grease on the inner tube.

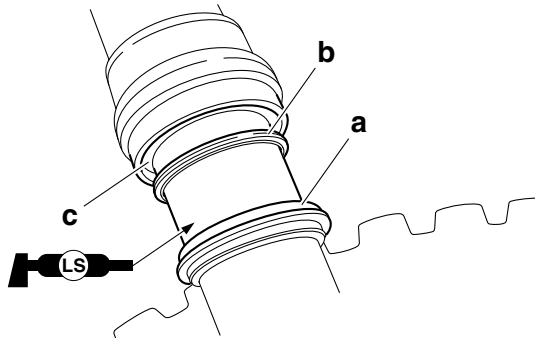

EAM30239

ADJUSTING THE FRONT FORK LEGS

EWA19180

⚠ WARNING

- Always adjust the left and right front forks evenly. If this is not done, the vehicle may have poor stability.
- Securely support the vehicle so that there is no danger of it falling over.

Rebound damping

ECA24340

NOTICE

Do not turn the adjuster forcibly beyond its adjusting range.

1. Adjust:
 - Rebound damping
 - a. Turn the adjuster "1" in the direction of "a" or "b" to make an adjustment.

Direction "a"
Rebound damping is increased (suspension is harder).
Direction "b"
Rebound damping is decreased (suspension is softer).



Rebound damping
Minimum (soft)
20 click(s) in direction "b"*
Standard
9 click(s) in direction "b"*
Maximum (hard)
0 click(s) in direction "b"*
* With the adjusting screw fully turned in direction "a"

TIP
Although the total number of clicks of a damping force adjusting mechanism may not exactly match the above specifications due to small dif-

ferences in production, the actual number of clicks always represents the entire adjusting range. To obtain a precise adjustment, it would be advisable to check the number of clicks of each damping force adjusting mechanism and to modify the specifications as necessary.

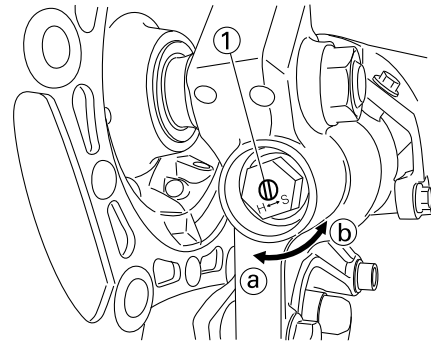

Compression damping

ECA24350

NOTICE

Do not turn the adjuster forcibly beyond its adjusting range.

1. Adjust:
 - Compression damping
 - a. Turn the adjuster "1" in the direction of "a" or "b" to make an adjustment.

Direction "a"
Compression damping is increased (suspension is harder).
Direction "b"
Compression damping is decreased (suspension is softer).



Compression damping
Minimum (soft)
20 click(s) in direction "b"*
Standard
10 click(s) in direction "b"*
Maximum (hard)
0 click(s) in direction "b"*
* With the adjusting screw fully turned in direction "a"

TIP
Although the total number of clicks of a damping force adjusting mechanism may not exactly match the above specifications due to small differences in production, the actual number of clicks always represents the entire adjusting range. To obtain a precise adjustment, it would be advisable to check the number of clicks of each damping force adjusting mechanism and

to modify the specifications as necessary.

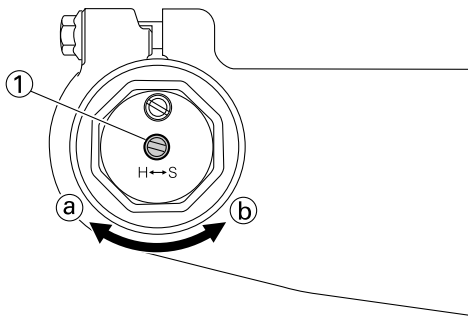

Air bleeding from front fork

TIP

If the front fork initial movement feels stiff during a run, relieve the front fork internal pressure.

1. Use a maintenance stand to raise the front wheel off the ground.

EWA13120



WARNING

Securely support the vehicle so that there is no danger of it falling over.

2. Remove the bleed screw "1" and release the internal pressure from the front fork.
3. Tighten:
 - Bleed screw



Bleed screw (front fork)
1.3 N·m (0.13 kgf·m, 0.95 lb-ft)

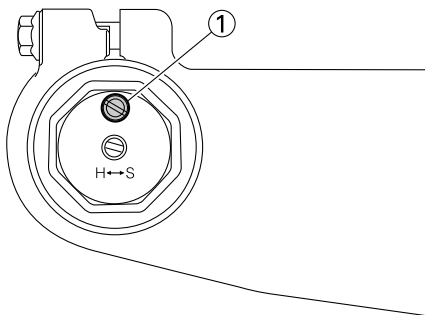

EAM30482

CHECKING THE REAR SHOCK ABSORBER ASSEMBLY

1. Stand the vehicle upright on a level surface.

EWA13120



WARNING

Securely support the vehicle so that there is no danger of it falling over.

2. Check:
 - Rear shock absorber assembly
 Gas leaks/oil leaks → Replace the rear shock absorber assembly.

Refer to "REAR SHOCK ABSORBER ASSEMBLY" on page 4-28.

3. Check:

- Rear shock absorber assembly smooth action
- Rear suspension link smooth action
 Sit astride the seat and shake your body up and down several times to check whether the rear shock absorber assembly operates smoothly.
 Unsmooth operation → Correct or replace.

EAM30242

ADJUSTING THE REAR SHOCK ABSORBER ASSEMBLY

Use a maintenance stand to raise the rear wheel off the ground.

EWA13120



WARNING

Securely support the vehicle so that there is no danger of it falling over.

Spring preload

ECA24360



NOTICE

Do not turn the adjuster forcibly beyond its adjusting range.

1. Remove:
 - Rear frame
2. Adjust:
 - Spring preload
 - a. Loosen the locknut "1".
 - b. Loosen the adjuster "2" until there is some clearance between the spring and the adjuster.
 - c. Measure the spring free length "a".

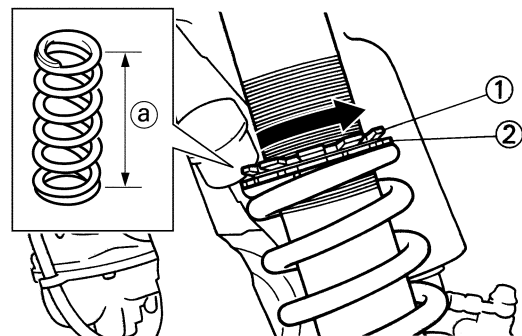

- d. Turn the adjuster in the direction of "b" or "c" to make an adjustment.

Direction “b”

Spring preload is increased (suspension is harder).

Direction “c”

Spring preload is decreased (suspension is softer).

Direction “a”

Rebound damping is increased (suspension is harder).

Direction “b”

Rebound damping is decreased (suspension is softer).



Spring preload adjusting positions

Minimum

Position in which the spring is turned in 1.5 mm (0.06 in) from its free length.

Standard

Position in which the spring is turned in 8.0 mm (0.31 in) from its free length.

Maximum

Position in which the spring is turned in 18.5 mm (0.73 in) from its free length.



Rebound damping

Minimum (soft)

20 click(s) in direction “b”*

Standard

9 click(s) in direction “b”*

Maximum (hard)

0 click(s) in direction “a”

* With the adjusting screw fully turned in direction “a”

TIP

- Be sure to remove all dirt and mud from around the locknut and adjusting ring before adjustment.
- The length of the spring (installed) changes 1.5 mm (0.06 in) per turn of the adjusting ring.

TIP

Although the total number of clicks of a damping force adjusting mechanism may not exactly match the above specifications due to small differences in production, the actual number of clicks always represents the entire adjusting range. To obtain a precise adjustment, it would be advisable to check the number of clicks of each damping force adjusting mechanism and to modify the specifications as necessary.

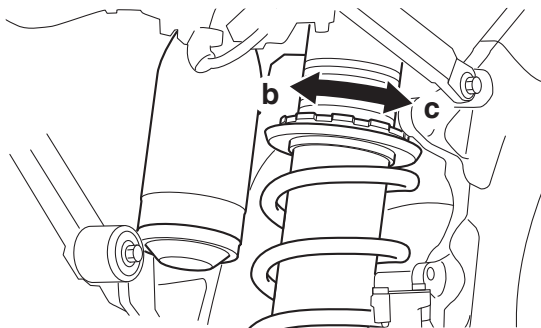

e. Tighten the locknut.

3. Install:

- Rear frame

Rebound damping

ECA24370

NOTICE

Do not turn the adjuster forcibly beyond its adjusting range.

1. Adjust:

- Rebound damping
 - a. Turn the adjuster “1” in the direction of “a” or “b” to make an adjustment.

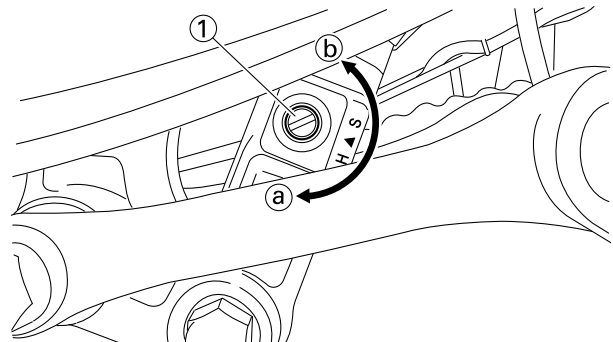

Compression damping (for fast compression damping)

ECA24370

NOTICE

Do not turn the adjuster forcibly beyond its adjusting range.

1. Adjust:

- Compression damping (for fast compression damping)
 - a. Turn the adjuster “1” in the direction of “a” or “b” to make an adjustment.

Direction “a”
 Compression damping is increased
 (suspension is harder).
Direction “b”
 Compression damping is decreased
 (suspension is softer).



Fast compression damping
Minimum (soft)
 2 turn(s) in direction “b”^{*}
Standard
 1 turn(s) in direction “b”^{*}
Maximum (hard)
 0 turn(s) in direction “b”^{*}
^{*}With the adjusting screw fully turned in direction “a”

TIP
 To obtain a precise adjustment, it is advisable to check the actual total number of turns of the damping force adjusting mechanism. This adjustment range may not exactly match the specifications listed due to small differences in production.

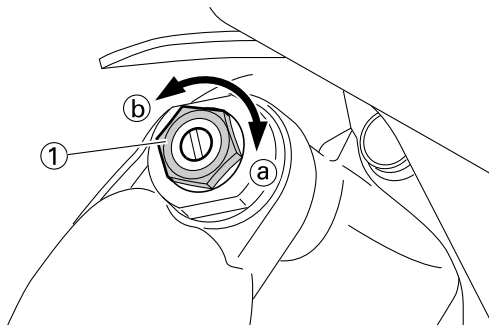

Compression damping (for slow compression damping)

ECA24390

NOTICE

Do not turn the adjuster forcibly beyond its adjusting range.

1. Adjust:
 - Compression damping (for slow compression damping)
 - a. Turn the adjuster “1” in the direction of “a” or “b” to make an adjustment.

Direction “a”
 Compression damping is increased
 (suspension is harder).
Direction “b”
 Compression damping is decreased
 (suspension is softer).



Slow compression damping
Minimum (soft)
 20 click(s) in direction “b”^{*}
Standard
 8 click(s) in direction “b”^{*}
Maximum (hard)
 0 click(s) in direction “b”^{*}

^{*}With the adjusting screw fully turned in direction “a”

TIP
 Although the total number of clicks of a damping force adjusting mechanism may not exactly match the above specifications due to small differences in production, the actual number of clicks always represents the entire adjusting range. To obtain a precise adjustment, it would be advisable to check the number of clicks of each damping force adjusting mechanism and to modify the specifications as necessary.

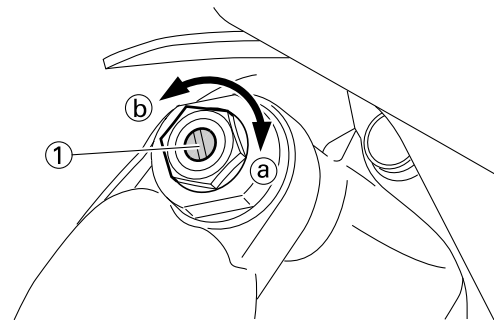

EAM30240

CHECKING THE SWINGARM OPERATION

1. Check:
 - Swingarm smooth action
 - Swingarm free play
 Refer to “SWINGARM” on page 4-29.

EAM30500

LUBRICATING THE SWINGARM PIVOT

1. Lubricate:
 - Oil seal
 - Collar



Recommended lubricant
Lithium-soap-based grease

EAM30243

CHECKING THE TIRES

1. Measure:
 - Tire pressure
 Out of specification → Regulate.



Tire air pressure (measured on cold tires)

Front

100 kPa (1.00 kgf/cm², 15 psi)

Rear

100 kPa (1.00 kgf/cm², 15 psi)

TIP

- Check the tire while it is cold.
- Because if the bead stopper tightening nut is loose when the tire pressure is low, the tire could slip off the rim, thus be sure to check and tighten the bead stopper tightening nut “a”.
- If the tire valve stem “b” is found tilted, the tire is considered to be slipping off its position. Correct the tire position.

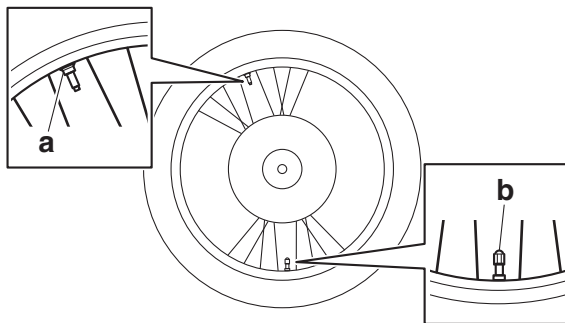

- a. Bead stopper tightening nut
b. Tire valve stem

EAM30244

CHECKING AND TIGHTENING THE SPOKES

1. Check:

- Spoke
Bend/damage → Replace.
Loose → Tighten.
Tap the spokes with a screwdriver.

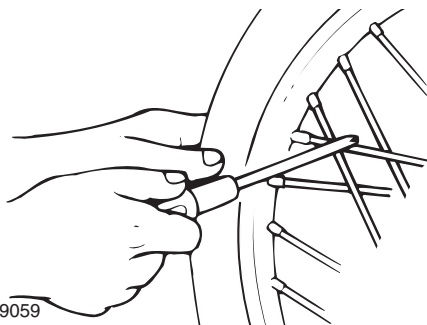

G089059

TIP

A tight spoke will emit a clear, ringing tone; a loose spoke will sound flat.

2. Tighten:

- Spoke
(with a spoke nipple wrench “1”)

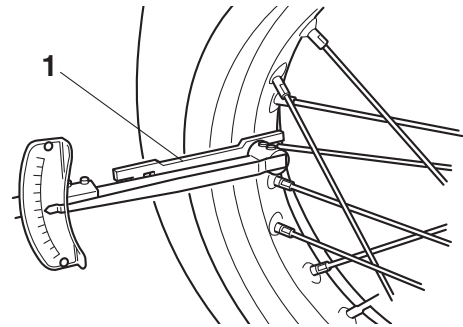

G089060



Spoke nipple wrench (6-7)

90890-01521

Spoke nipple wrench (6-7)

YM-01521



Nipple (spoke)

2.5 N·m (0.25 kgf·m, 1.8 lb·ft)

TIP

- Do not give a half turn (180°) or more for one tightening.
- Make sure that tightening after a break-in is done until the initial looseness in nipples disappears.
- Make sure that tightening is done in stages, not at a time.

EAM30245

CHECKING THE WHEELS

1. Check:

- Wheel
Damage/out-of-round → Replace.

EWA13260



WARNING

Never attempt to make any repairs to the wheel.

EAM30253

CHECKING THE CHASSIS FASTENERS

Make sure that all nuts, bolts, and screws are properly tightened.

Refer to “CHASSIS TIGHTENING TORQUES” on page 2-9.

EAM30248

CHECKING AND LUBRICATING THE CABLES

The following procedure applies to all of the inner and outer cables.

EWA13270



WARNING

Damaged outer cable may cause the cable to corrode and interfere with its movement. Replace damaged outer cable and inner cables

as soon as possible.

1. Check:
 - Outer cable
Damage → Replace.
2. Check:
 - Cable operation
Rough movement → Lubricate.



TIP

Hold the cable end upright and pour a few drops of lubricant into the cable sheath or use a suitable lubricating device.

EAM30483

LUBRICATING THE BRAKE LEVER

1. Lubricate the pivoting points and metal-to-metal moving parts of the following parts.
 - Brake lever



EAM30503

LUBRICATING THE CLUTCH LEVER

1. Lubricate the pivoting points and metal-to-metal moving parts of the following parts.
 - Clutch lever



EAM30250

LUBRICATING THE PEDAL

1. Lubricate the pivoting point and metal-to-metal moving parts of the pedal.



EAM30504

CHECKING THE SIDESTAND

1. Check:
 - Sidestand operation
Check that the sidestand moves smoothly.
Rough movement → Repair or replace.

EAM30252

LUBRICATING THE SIDESTAND

Lubricate the pivoting point and metal-to-metal moving parts of the sidestand.

CHASSIS

GENERAL CHASSIS	4-1
REMOVING THE NUMBER PLATE.....	4-1
REMOVING THE SIDE COVER.....	4-1
FRONT WHEEL	4-2
REMOVING THE FRONT WHEEL.....	4-2
INSTALLING THE FRONT WHEEL.....	4-2
REAR WHEEL	4-3
REMOVING THE REAR WHEEL.....	4-3
CHECKING AND REPLACING THE REAR WHEEL SPROCKET.....	4-3
INSTALLING THE REAR WHEEL.....	4-3
FRONT BRAKE	4-5
REPLACING THE FRONT BRAKE PADS.....	4-5
REAR BRAKE	4-7
REPLACING THE REAR BRAKE PADS.....	4-7
HANDLEBAR	4-9
REMOVING THE HANDLEBAR.....	4-9
CHECKING THE HANDLEBAR.....	4-9
INSTALLING THE HANDLEBAR.....	4-9
FRONT FORK	4-14
REMOVING THE FRONT FORK LEGS.....	4-14
DISASSEMBLING THE FRONT FORK LEGS.....	4-14
CHECKING THE FRONT FORK LEGS.....	4-15
ASSEMBLING THE FRONT FORK LEGS.....	4-16
INSTALLING THE FRONT FORK LEGS.....	4-22
STEERING HEAD	4-25
REMOVING THE LOWER BRACKET.....	4-25
CHECKING THE STEERING HEAD.....	4-25
INSTALLING THE STEERING HEAD.....	4-25
REAR SHOCK ABSORBER ASSEMBLY	4-28
REMOVING THE REAR SHOCK ABSORBER ASSEMBLY.....	4-28
CHECKING THE REAR SHOCK ABSORBER ASSEMBLY.....	4-28
SWINGARM	4-29
REMOVING THE SWINGARM.....	4-29
CHAIN DRIVE	4-30
REMOVING THE DRIVE CHAIN.....	4-30

CHECKING THE DRIVE CHAIN	4-30
CHECKING THE DRIVE SPROCKET	4-31
CHECKING THE REAR WHEEL SPROCKET	4-31
INSTALLING THE DRIVE CHAIN	4-31

EAM20094

GENERAL CHASSIS

EAM30371

REMOVING THE NUMBER PLATE

1. Remove:

- Number plate bolt
- Number plate "1"

TIP

- The projection "a" is inserted into the band of the number plate. Pull the band off the projection before removal.
- Remove the clutch cable "2" from the cable guide "b" on the number plate.
- The projection "c" on the lower bracket is inserted into the number plate. Remove the number plate by pulling it off the projection.
- When installing the number plate, insert the projection on the number plate into the hole in the upper side of the band.

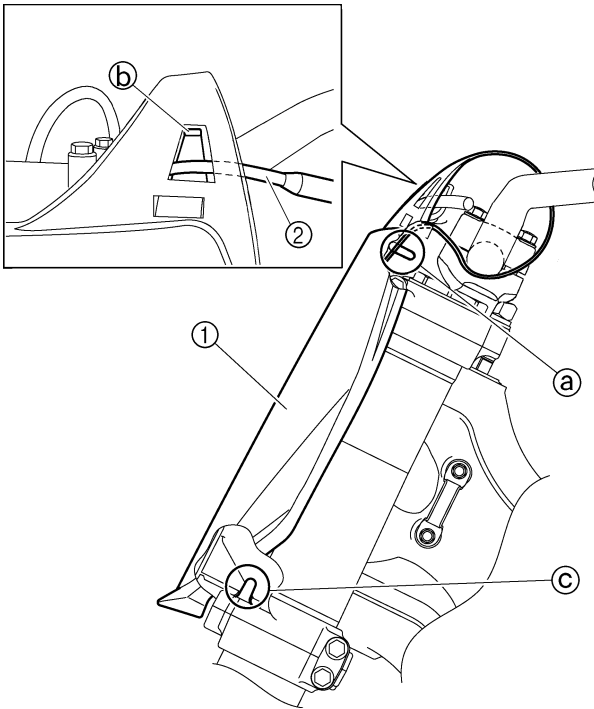
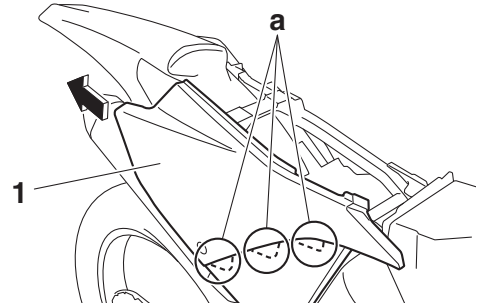
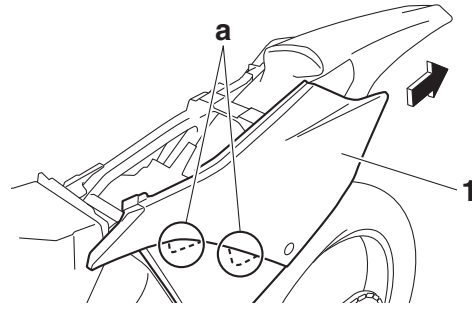

EAM30459

REMOVING THE SIDE COVER

1. Remove:

- Side cover bolt
- Side cover (left and right) "1"

TIP

Draw the side cover backward to remove it because its claws "a" are inserted in the air filter case.

FRONT WHEEL

EAM20095

FRONT WHEEL

EAM30017

REMOVING THE FRONT WHEEL

1. Use a maintenance stand to raise the front wheel off the ground.

EWA13120

WARNING

Securely support the vehicle so that there is no danger of it falling over.

2. Remove:
 - Front wheel

EAM30617

INSTALLING THE FRONT WHEEL

1. Install:
 - Front wheel

TIP

Install the brake disc "1" between the brake pads "2" correctly.

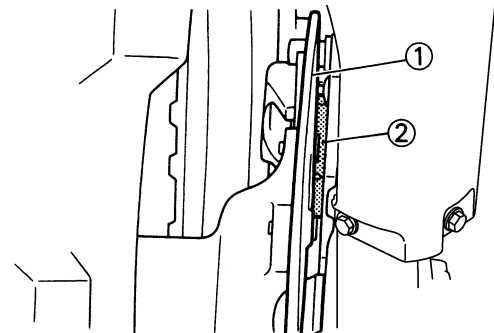

2. Install:
 - Front wheel axle "1"

TIP

Apply the lithium-soap-based grease to the front wheel axle.

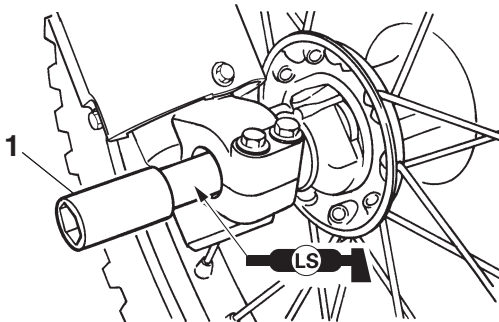

3. Tighten:
 - Front wheel axle nut "1"



Front wheel axle nut
105 N·m (10.5 kgf·m, 77 lb·ft)

ECA24430

NOTICE

Before tightening the front wheel axle nut, push down hard on the handlebar(s) several times and check if the front fork rebounds smoothly.

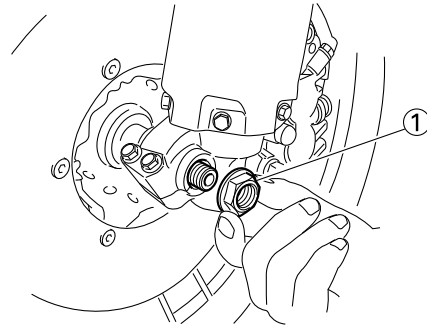

4. Tighten:
 - Front wheel axle pinch bolt "1"



Front wheel axle pinch bolt
21 N·m (2.1 kgf·m, 15 lb·ft)

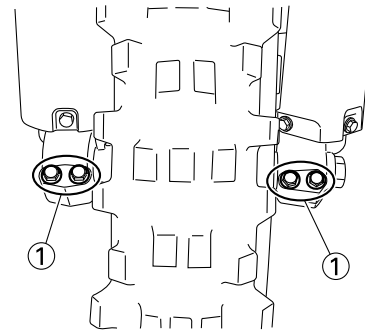

EAM20096

REAR WHEEL

EAM30022

REMOVING THE REAR WHEEL

1. Use a maintenance stand to raise the rear wheel off the ground.

EWA13120

WARNING

Securely support the vehicle so that there is no danger of it falling over.

2. Remove:
 - Rear wheel axle nut "1"
3. Loosen:
 - Locknut "2"
4. Tighten:
 - Adjusting bolt "3"

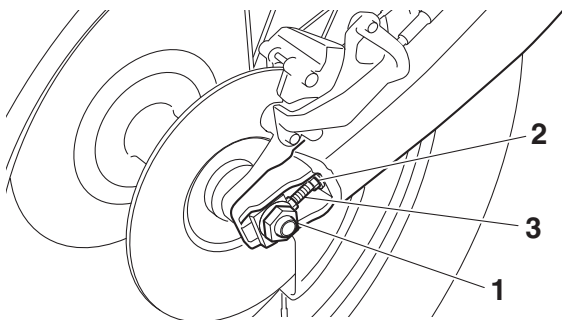

5. Remove:
 - Rear wheel axle
 - Rear wheel

TIP

- Push the rear wheel forward and remove the drive chain from the rear wheel sprocket.
- Do not depress the brake pedal with the rear wheel removed.

EAM30025

CHECKING AND REPLACING THE REAR WHEEL SPROCKET

1. Check:
 - Rear wheel sprocket
 - More than 1/4 tooth wear "a" → Replace the rear wheel sprocket and the drive sprocket as a set.
 - Bent tooth → Replace the rear wheel sprocket and the drive sprocket as a set.

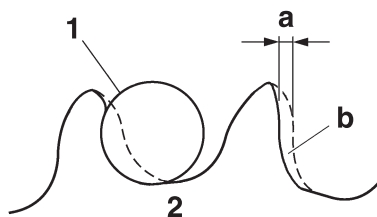

G088904

- Correct
 1. Drive chain roller
 2. Rear wheel sprocket

2. Replace:
 - Rear wheel sprocket
 - a. Remove the self-locking nuts and the rear wheel sprocket.
 - b. Clean the rear wheel drive hub with a clean cloth, especially the surfaces that contact the sprocket.
 - c. Install the new rear wheel sprocket.



Rear wheel sprocket nut
42 N·m (4.2 kgf·m, 31 lb·ft)

TIP

Tighten the self-locking nuts in stages and in a crisscross pattern.

EAM30027

INSTALLING THE REAR WHEEL

1. Install:
 - Rear wheel

TIP

Install the brake disc "1" between the brake pads "2" correctly.

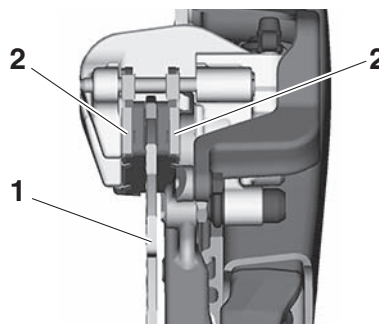

2. Install:
 - Drive chain "1"

TIP

Push the rear wheel "2" forward and install the drive chain.

REAR WHEEL

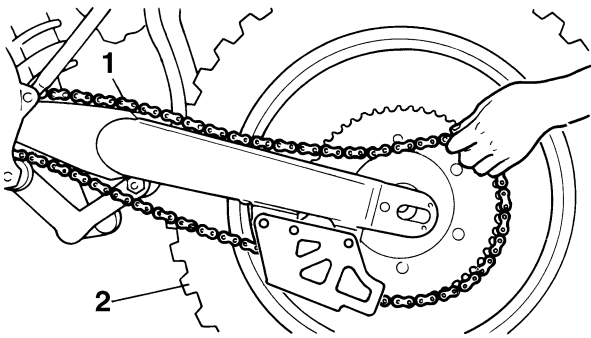

3. Install:

- Drive chain puller (left) "1"
- Rear wheel axle "2"

TIP

- Install the drive chain puller (left), and insert the rear wheel axle from the left side.
- Apply the lithium-soap-based grease to the rear wheel axle.

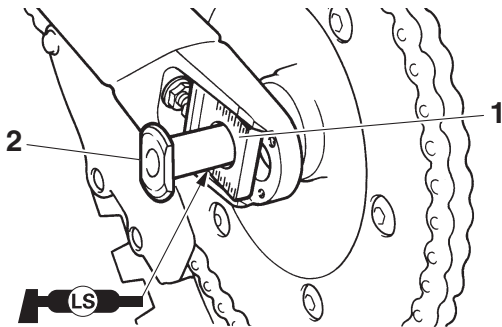

4. Install:

- Drive chain puller (right) "1"
- Washer "2"
- Rear wheel axle nut "3"

TIP

Temporarily tighten the rear wheel axle nut at this point.

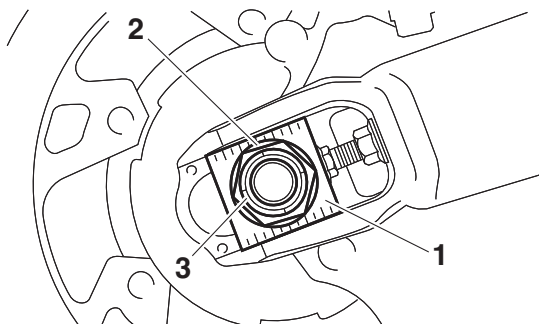

5. Adjust:

- Drive chain slack "a"

	<p>Drive chain slack (Maintenance Stand) 48.0–58.0 mm (1.89–2.28 in)</p>
--	---

Refer to "DRIVE CHAIN SLACK" on page 3-16.

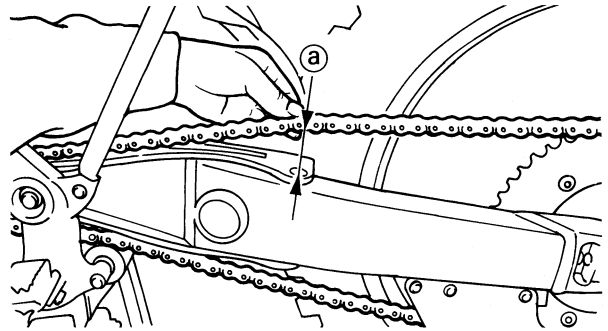

6. Tighten:

- Rear wheel axle nut "1"

	<p>Rear wheel axle nut 125 N·m (12.5 kgf·m, 92 lb·ft)</p>
--	--

- Locknut "2"

	<p>Drive chain puller locknut 19 N·m (1.9 kgf·m, 14 lb·ft)</p>
--	---

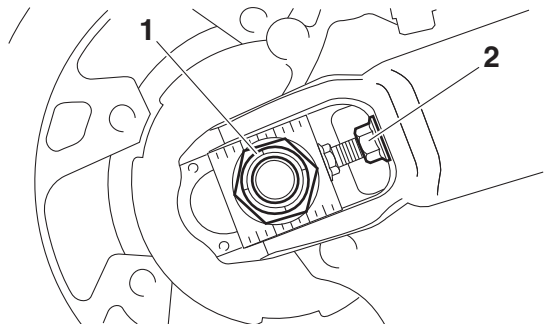

EAM20097

FRONT BRAKE

EAM30519

REPLACING THE FRONT BRAKE PADS

TIP

When replacing the brake pads, it is not necessary to disconnect the brake hose or disassemble the brake caliper.

1. Remove:

- Brake pad
 - a. Remove the pad pin plug "1".

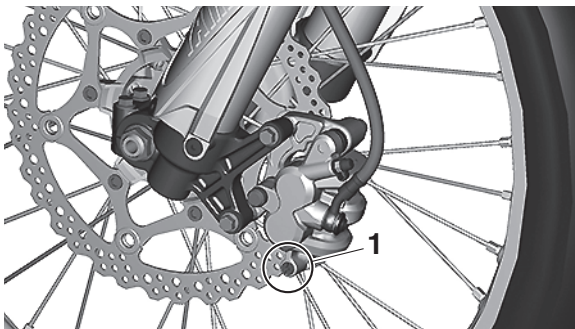

- b. Loosen the pad pin "2".
- c. Remove the brake caliper "3" from the front fork.

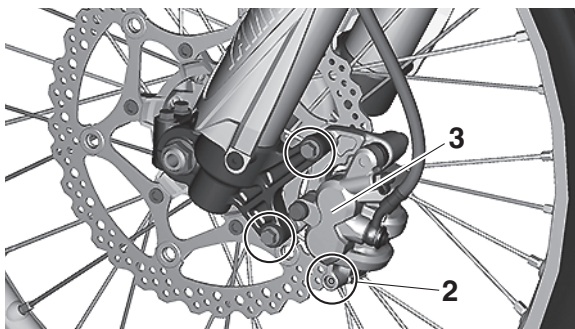

- d. Remove the pad pin and brake pads "4".

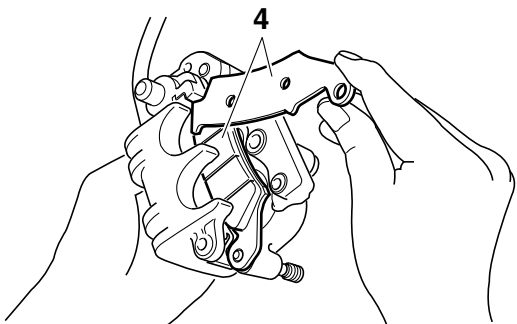

2. Measure:

- Brake pad wear limit "a"
Out of specification → Replace the brake pads as a set.



**Brake pad lining thickness limit
1.0 mm (0.04 in)**

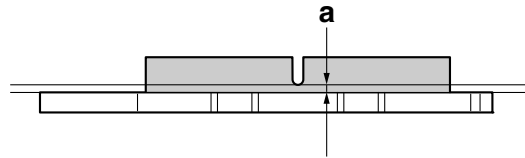

3. Install:

- Brake pad
 - a. Connect the plastic hose "1" to the bleed screw "2" and place a container under the end of the plastic hose.

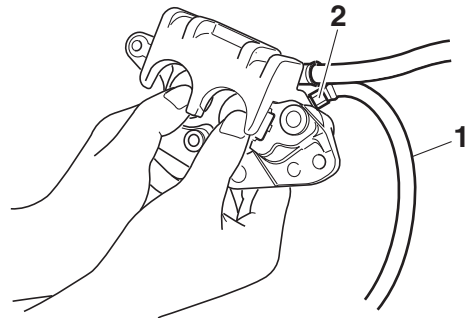

- b. Loosen the bleed screw and push the brake caliper piston in.

EWA19160

⚠ WARNING

Do not reuse the drained brake fluid.

- c. Tighten the bleed screw.



**Brake caliper bleed screw
6 N·m (0.6 kgf·m, 4.4 lb·ft)**

- d. Install the brake pads "3" and the pad pin.

TIP

- Install the brake pads with their projections "a" into the brake caliper recesses "b".
- Temporarily tighten the pad pin at this point.

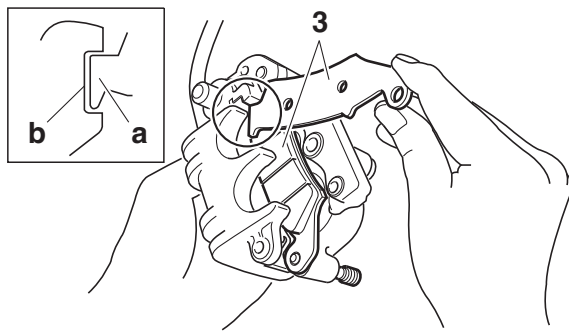

e. Install the brake caliper “4” and tighten the pad pin “5”.

	Front brake caliper bolt 28 N·m (2.8 kgf·m, 21 lb·ft)
	Brake pad pin 17 N·m (1.7 kgf·m, 13 lb·ft)

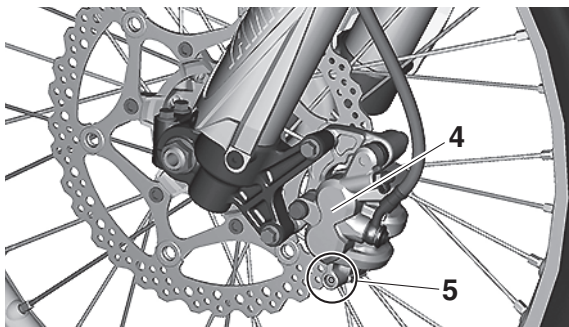

f. Install the pad pin plug “6”.

	Brake pad pin plug 2.5 N·m (0.25 kgf·m, 1.8 lb·ft)
---	---

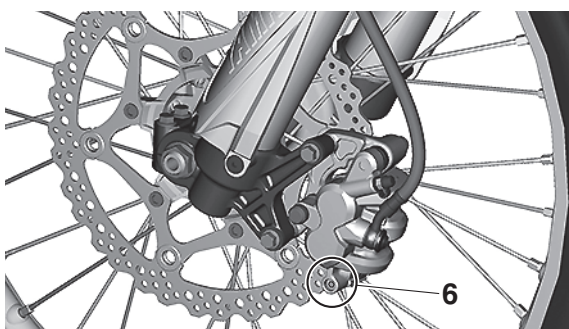

4. Check:
- Brake fluid level
Refer to “CHECKING THE BRAKE FLUID LEVEL” on page 3-14.
5. Check:
- Brake lever operation
A softy or spongy feeling → Bleed the brake system.
Refer to “BLEEDING THE HYDRAULIC BRAKE SYSTEM” on page 3-15.

EAM20098

REAR BRAKE

EAM30523

REPLACING THE REAR BRAKE PADS

TIP

When replacing the brake pads, it is not necessary to disconnect the brake hose or disassemble the brake caliper.

1. Remove:

- Brake pad
 - a. Remove the protector "1" and the pad pin plug "2".

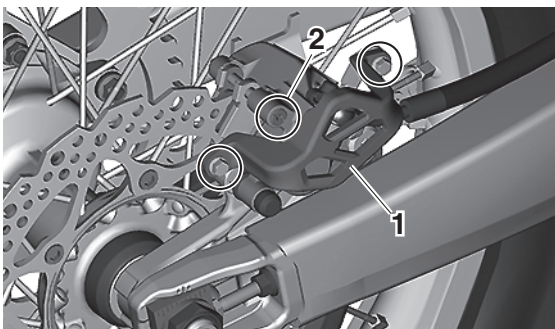

- b. Loosen the pad pin "3".
- c. Remove the rear wheel "4" and the brake caliper "5".

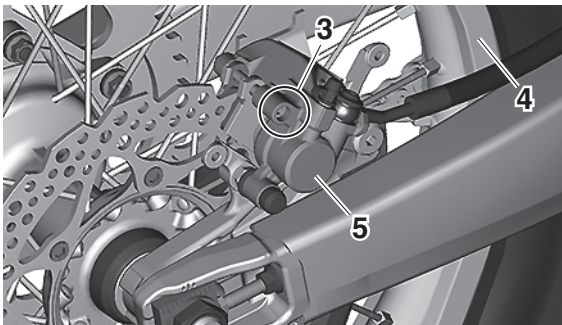

- d. Remove the pad pin "6" and the brake pads "7".

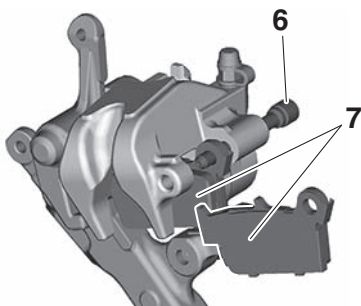

2. Measure:

- Brake pad wear limit "a"
Out of specification → Replace the brake pads as a set.



**Brake pad lining thickness limit
1.0 mm (0.04 in)**

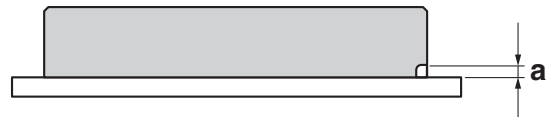

3. Install:

- Brake pad
 - a. Connect the plastic hose "1" to the bleed screw "2" and place a container under the end of the plastic hose.

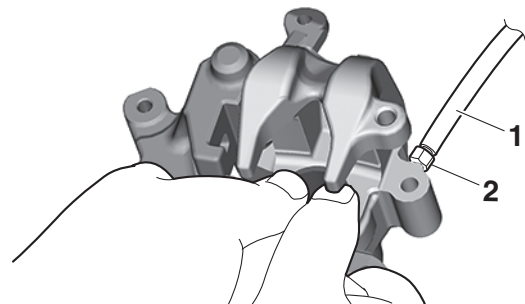

- b. Loosen the bleed screw and push the brake caliper piston in.

EWA19170

⚠ WARNING

Do not reuse the drained brake fluid.

- c. Tighten the bleed screw.



**Brake caliper bleed screw
6 N·m (0.6 kgf·m, 4.4 lb·ft)**

- d. Install the brake pad "3" and the pad pin "4".

TIP

- Install the brake pads with their projections "a" into the brake caliper recesses "b".
- Temporarily tighten the pad pin at this point.

REAR BRAKE

Refer to "BLEEDING THE HYDRAULIC BRAKE SYSTEM" on page 3-15.

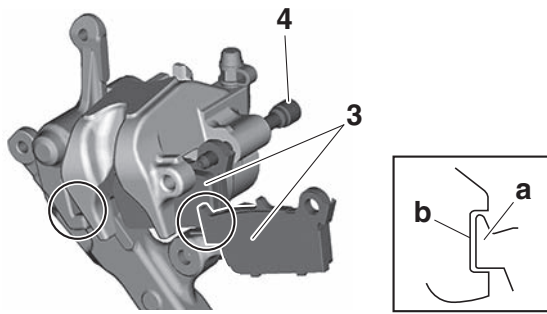

- e. Install the brake caliper "5" and the rear wheel "6".
- f. Tighten the pad pin "7".

	Brake pad pin 17 N·m (1.7 kgf·m, 13 lb-ft)
---	--

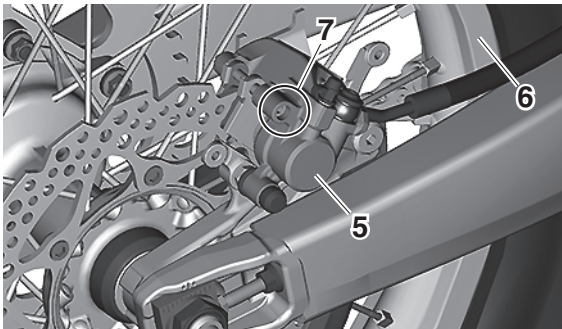

- g. Install the pad pin plug "8" and the protector "9".

	Brake pad pin plug 2.5 N·m (0.25 kgf·m, 1.8 lb-ft) Rear brake caliper protector bolt 7 N·m (0.7 kgf·m, 5.2 lb-ft)
---	--

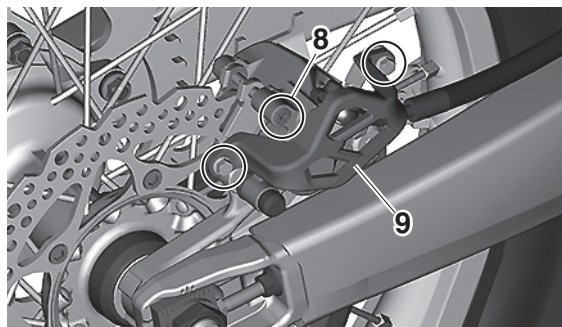

- 4. Check:
 - Brake fluid level
Refer to "CHECKING THE BRAKE FLUID LEVEL" on page 3-14.
- 5. Check:
 - Brake pedal operation
A softy or spongy feeling → Bleed the brake system.

EAM20099

HANDLEBAR

EAM30052

REMOVING THE HANDLEBAR

1. Stand the vehicle upright on a level surface.

EWA13120

WARNING

Securely support the vehicle so that there is no danger of it falling over.

2. Remove:

- Grip "1"

TIP

Blow in compressed air between the handlebar or tube guide and the grip. Then remove the grip which has become loose.

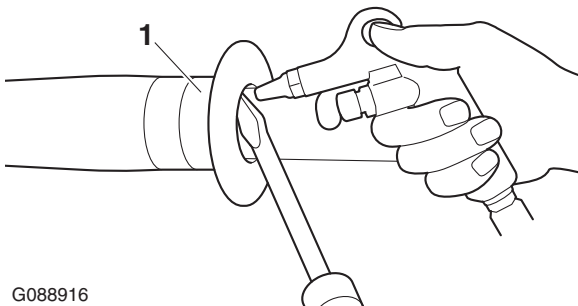

G088916

3. Remove:

- Throttle cable housing "1"
- Throttle grip "2"

TIP

While removing the throttle cable housing, pull back the rubber cover "3".

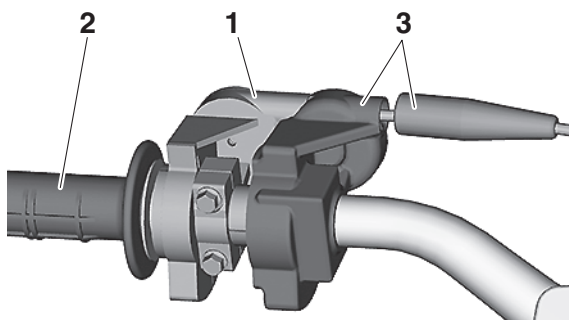

EAM30053

CHECKING THE HANDLEBAR

1. Check:

- Handlebar
Bends/cracks/damage → Replace.

EWA13690

WARNING

Do not attempt to straighten a bent handlebar as this may dangerously weaken it.

EAM30054

INSTALLING THE HANDLEBAR

1. Stand the vehicle upright on a level surface.

EWA13120

WARNING

Securely support the vehicle so that there is no danger of it falling over.

2. Install:

- Lower handlebar holder "1"
- Washer "2"
- Lower handlebar holder nut "3"

TIP

- Install the lower handlebar holders with them side having the greater distance "a" from the mounting bolt center facing forward.
- Apply the lithium-soap-based grease on the thread of the lower handlebar holders.
- Installing the lower handlebar holders in the reverse direction allow the front-to-rear offset amount of the handlebar position to be changed.
- Do not tighten the nuts yet.

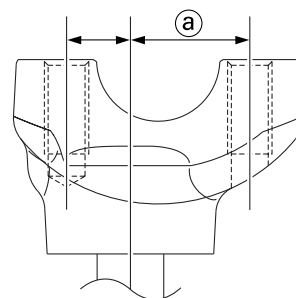
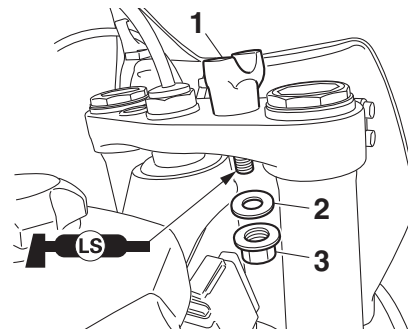

3. Install:

- Handlebar "1"
- Upper handlebar holder "2"
- Upper handlebar holder bolt "3"



**Upper handlebar holder bolt
28 N·m (2.8 kgf·m, 21 lb·ft)**

TIP

- The upper handlebar holders should be in-

HANDLEBAR

stalled with the punch marks “a” facing forward.

- Install the handlebar so that the marks “b” are in place on both sides.
- Install the handlebar so that the projection “c” of the upper handlebar holders is positioned at the mark on the handlebar as shown.
- First tighten the bolts on the front side of the upper handlebar holder, and then tighten the bolts on the rear side.

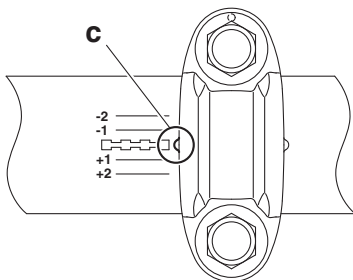
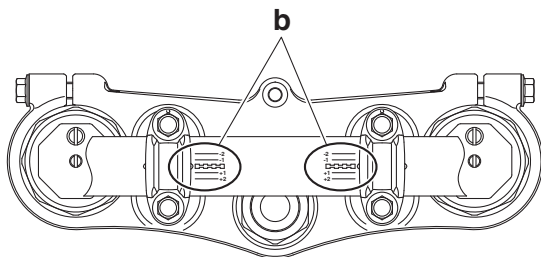
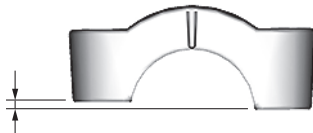
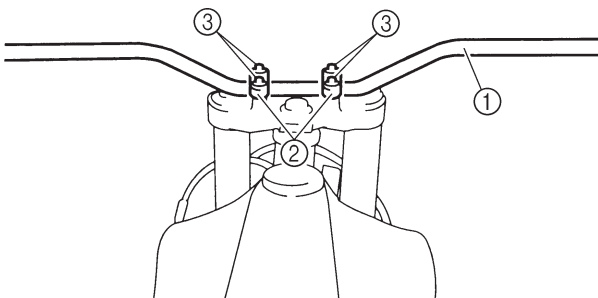

4. Tighten:

- Lower handlebar holder nut “1”



Lower handlebar holder nut
40 N·m (4.0 kgf·m, 30 lb·ft)

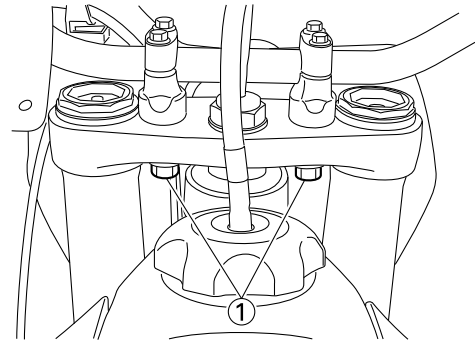

5. Install:

- Left grip “1”

Apply the adhesive to the handlebar “2”.

TIP

- Before applying the adhesive, wipe off grease or oil on the handlebar surface “a” with a lacquer thinner.
- Install the left grip to the handlebar so that the line “b” between the two arrow marks faces straight upward.

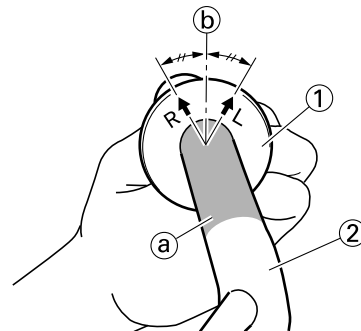

6. Install:

- Engine stop switch “1”



Engine stop switch screw
0.5 N·m (0.05 kgf·m, 0.37 lb·ft)

- Clutch lever holder “2”
- Clutch lever holder bolt “3”



Clutch lever holder bolt
5 N·m (0.5 kgf·m, 3.7 lb·ft)
Clutch lever nut
4.0 N·m (0.40 kgf·m, 3.0 lb·ft)

- Clamp “4”

TIP

- The engine stop switch, clutch lever holder and

clamp should be installed according to the dimensions shown.

- Pass the engine stop switch lead in the middle of the clutch lever holder.

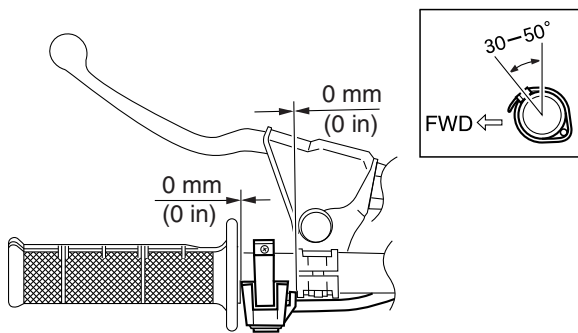
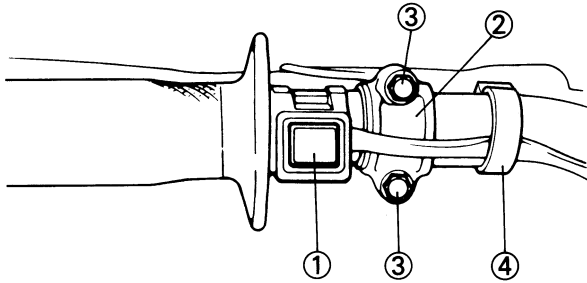

7. Install:

- Clutch cable "1"

TIP

Apply the lithium-soap-based grease on the clutch cable end.

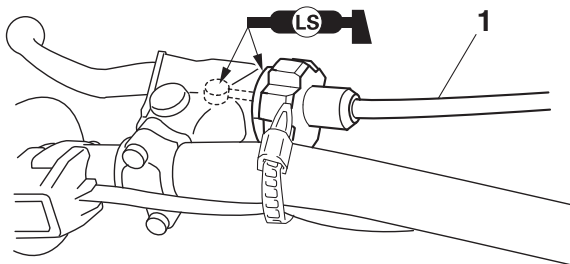

8. Adjust:

- Clutch lever free play
Refer to "ADJUSTING THE CLUTCH LEVER FREE PLAY" on page 3-7.

9. Install:

- Right grip "1"
Apply the adhesive on the tube guide "2".

TIP

- Before applying the adhesive, wipe off grease or oil on the tube guide surface "a" with a lacquer thinner.
- Align the mating mark "b" on the right grip with

the slot "c" in the tube guide.

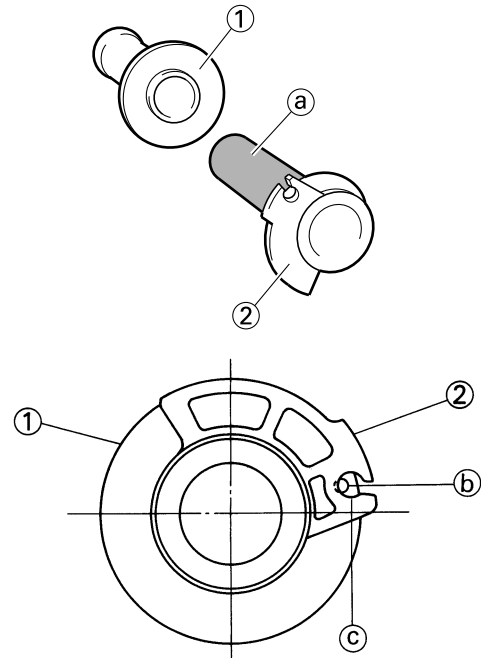

10. Install:

- Grip cap (upper) "1"
- Grip cap (lower) "2"
- Grip cap bolt "3"

TIP

Temporarily tighten the grip cap bolts.

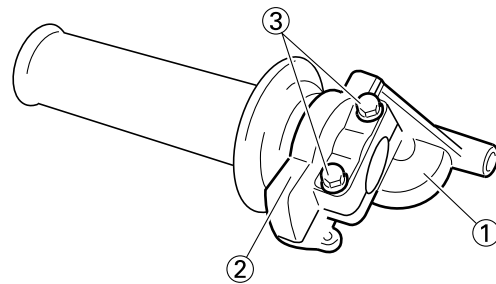

11. Install:

- Collar "1"
- Grip cap cover "2"
- Throttle grip "3"

TIP

- Apply the lithium-soap-based grease on the throttle grip sliding surface.
- Tighten the grip cap bolts temporarily without the throttle being fixed to the handlebar.

HANDLEBAR

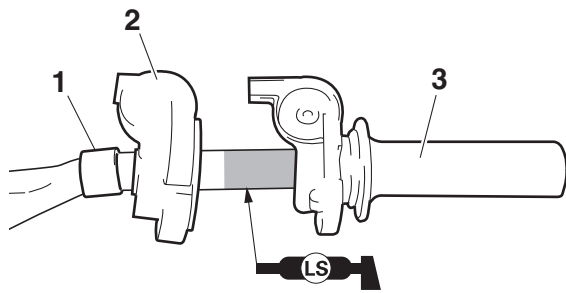

12. Install:

- Throttle cable “1”
(to the tube guide “2”)

TIP

Apply the lithium-soap-based grease on the throttle cable end and tube guide cable winding portion.

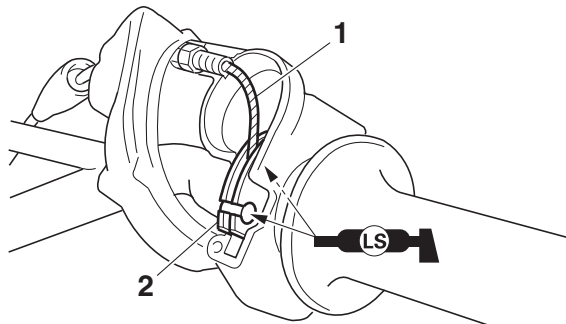

13. Install:

- Roller “1”
- Collar “2”

TIP

- Apply the lithium-soap-based grease on the roller sliding surface and cable guide.
- Install the roller so that the “UPPER” mark “a” faces upward.
- Pass the throttle cable in the groove “b” in the roller.

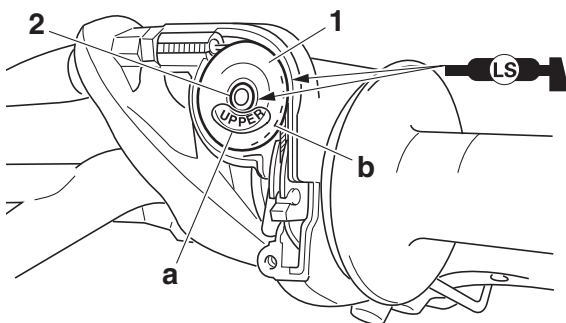

14. Install:

- Throttle cable cap “1”
- Throttle cable cap screw “2”



Throttle cable cap screw
0.5 N·m (0.05 kgf·m, 0.37 lb·ft)

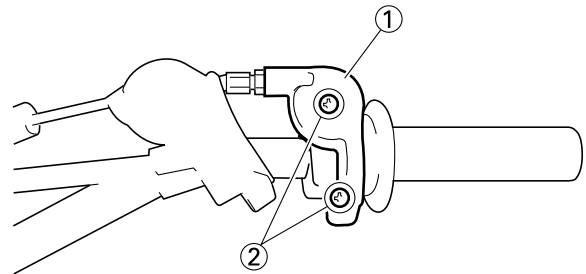

15. Adjust:

- Throttle grip free play
Refer to “CHECKING THE THROTTLE GRIP” on page 3-5.

16. Install:

- Cap cover “1”

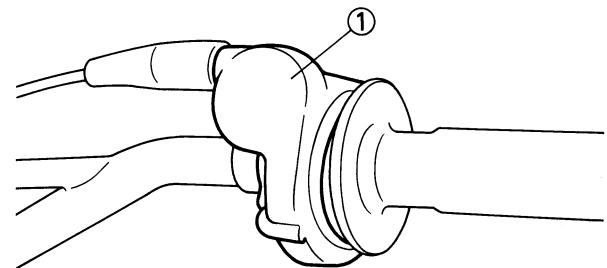

17. Install:

- Brake master cylinder “1”
- Brake master cylinder holder “2”
- Front brake master cylinder holder bolt “3”



Front brake master cylinder holder bolt
9 N·m (0.9 kgf·m, 6.6 lb·ft)

TIP

- Install the holder so that the arrow mark “a” faces upward.
- First tighten the bolt on the upper side of the brake master cylinder holder, and then tighten the bolt on the lower side.

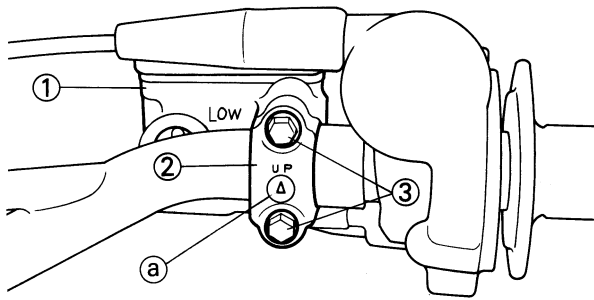

18. Install:

- Grip cap bolt "1"

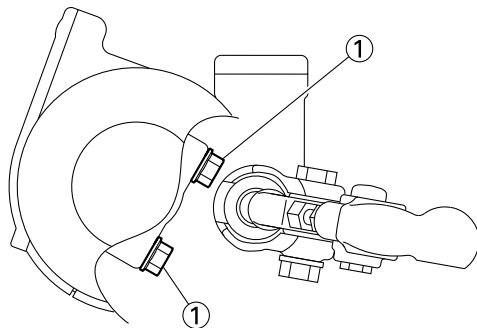
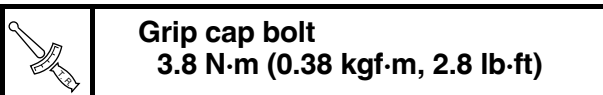

EWA21080

⚠ WARNING

After tightening the bolts, check that the throttle grip "2" moves smoothly. If it does not, retighten the bolts for adjustment.

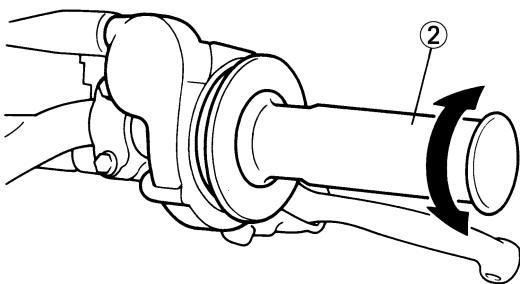

EAM20100

FRONT FORK

EAM30055

REMOVING THE FRONT FORK LEGS

1. Use a maintenance stand to raise the front wheel off the ground.

EWA13120

WARNING

Securely support the vehicle so that there is no danger of it falling over.

TIP

Record the adjusting screw setting position before loosening the adjuster and the base valve.

2. Loosen:
 - Upper bracket pinch bolt
 - Damper assembly
 - Lower bracket pinch bolt

EWA20350

WARNING

Before loosening the upper and lower bracket pinch bolts, support the front fork leg.

TIP

Before removing the front fork leg from the vehicle, loosen the damper assembly "1" with the cap bolt ring wrench "2".



Cap bolt ring wrench
90890-01501
Cap bolt ring wrench
YM-01501

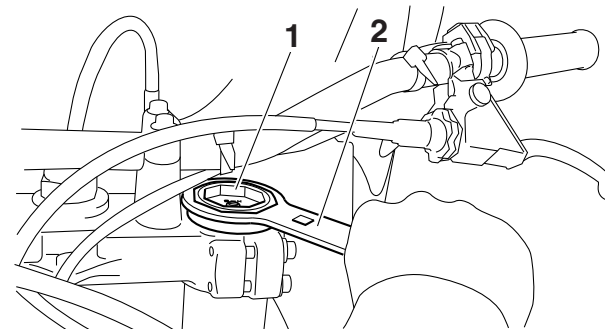

3. Remove:
 - Front fork leg

EAM30056

DISASSEMBLING THE FRONT FORK LEGS

1. Drain:
 - Fork oil
2. Remove:
 - Adjuster "1" (from the inner tube)

TIP

- While compressing the inner tube "2", set the cap bolt ring wrench "4" between the inner tube and locknut "3".
- Hold the locknut and remove the adjuster.

ECA24520

NOTICE

Do not remove the locknut as the damper rod may go into the damper assembly and not be taken out.



Cap bolt ring wrench
90890-01501
Cap bolt ring wrench
YM-01501

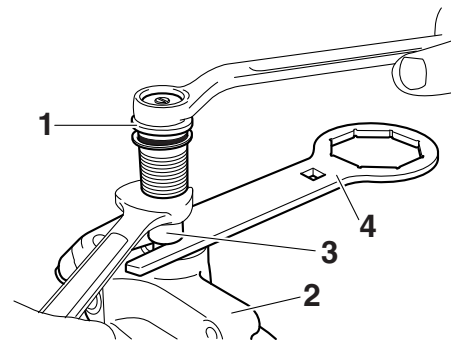

3. Remove:
 - Dust seal "1"
 - Stopper ring "2" (with a flat-head screwdriver)

ECA14180

NOTICE

Do not scratch the inner tube.

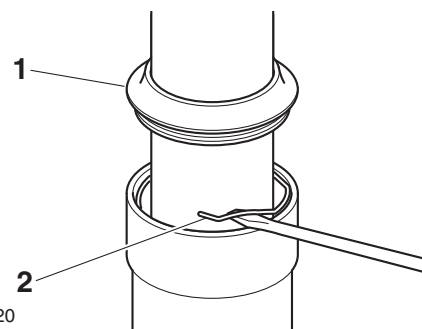

G088920

4. Remove:
 - Inner tube "1"

- a. Push in slowly "a" the inner tube just before it bottoms out and then pull it back quickly "b".
- b. Repeat this step until the inner tube can be pulled out from the outer tube.

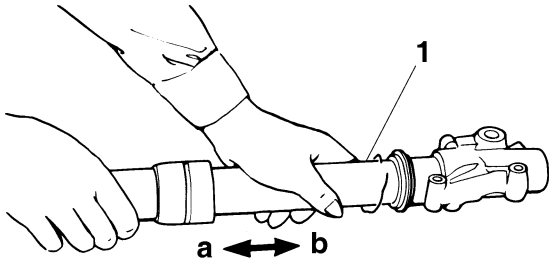

5. Remove:
- Base valve "1"
(from the damper assembly)

TIP

Hold the damper assembly with the cap bolt ring wrench "2" and use the cap bolt wrench "3" to remove the base valve.

	Cap bolt wrench 90890-01500
	Cap bolt wrench YM-01500
	Cap bolt ring wrench 90890-01501
	Cap bolt ring wrench YM-01501

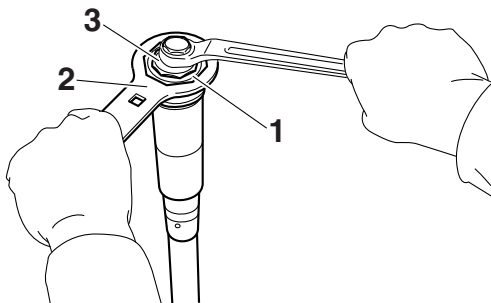

EAM30057

CHECKING THE FRONT FORK LEGS

1. Check:
- Inner tube surface
Scratches → Repair or replace.
Use #1000 grit wet sandpaper.
Damaged oil lock piece → Replace.
 - Inner tube bends
Out of specification → Replace.
Use the dial gauge.

	Inner tube bending limit 0.2 mm (0.01 in)
--	---

TIP

The bending value is shown by one half of the

dial gauge reading.

EWA13650

WARNING

Do not attempt to straighten a bent inner tube as this may dangerously weaken it.

2. Check:
- Outer tube
Scratches/wear/damage → Replace.
3. Measure:
- Fork spring free length "a"
Out of specification → Replace.



Fork spring free length limit
492.0 mm (19.37 in)

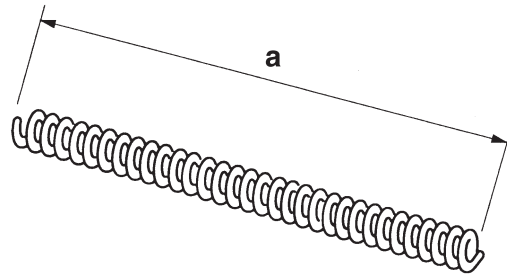

G088921

4. Check:
- Damper assembly "1"
Bend/damage → Replace.
 - O-ring "2"
Wear/damage → Replace.

ECA14200

NOTICE

- The front fork leg has a built-in damper adjusting rod and a very sophisticated internal construction, which are particularly sensitive to foreign material.
- When disassembling and assembling the front fork leg, do not allow any foreign material to enter the front fork.

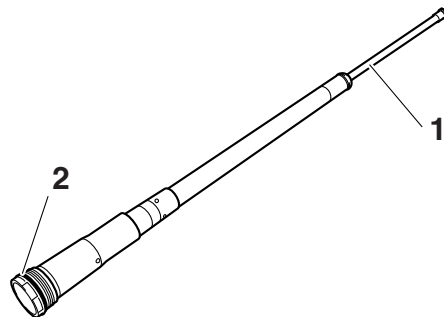

5. Check:
- Base valve "1"
Wear/damage → Replace.

FRONT FORK

Contamination → Clean.

- O-ring “2”
Wear/damage → Replace.
- Piston metal “3”
Wear/damage → Replace.
- Fork spring “4”
Damage/fatigue → Replace base valve.
- Bleed screw “5”
Wear/damage → Replace.

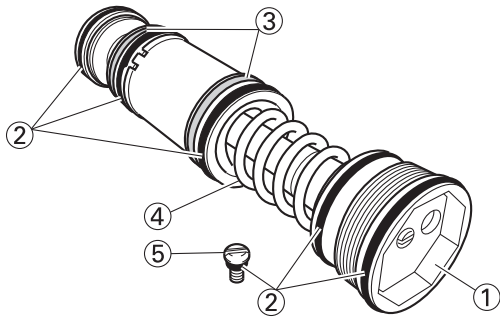

6. Check:

- Upper spring seat “1”
(contacting surface “a”)
Wear/damage → Replace.

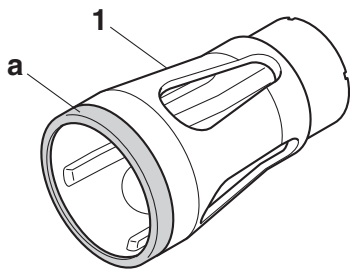

7. Check:

- Adjuster “1”
- O-ring “2”
Wear/damage → Replace.

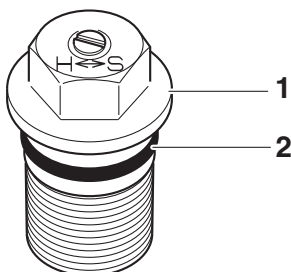

8. Check:

- Scraper “1”
Damage → Replace.

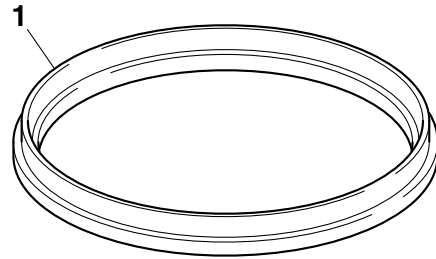

EAM30058

ASSEMBLING THE FRONT FORK LEGS

EWA13660

⚠ WARNING

- Make sure the oil levels in both front fork legs are equal.
- Uneven oil levels can result in poor handling and a loss of stability.

TIP

- When assembling the front fork leg, be sure to replace the following parts:
 - Inner tube bushing
 - Slide metal
 - Oil seal
 - Copper washer
- Before assembling the front fork leg, make sure that all of the components are clean.

1. Stretch the damper assembly fully.
2. Fill:
 - Damper assembly



Recommended oil
Yamaha Suspension Oil S1
Standard oil amount
205 cm³ (6.93 US oz, 7.21 Imp.oz)

ECA24530

NOTICE

- Be sure to use the recommended oil. Other oils may have an adverse effect on front fork performance.
- When disassembling and assembling the front fork leg, take care not to allow any foreign material to enter the front fork.

3. After filling, pump the damper assembly “1” slowly up and down (about 200 mm (7.9 in) stroke) several times to bleed the damper assembly of air.

TIP

Avoid excessive full stroke. A stroke of 200 mm (7.9 in) or more will cause air to enter. In this case, repeat the steps (1) to (3).

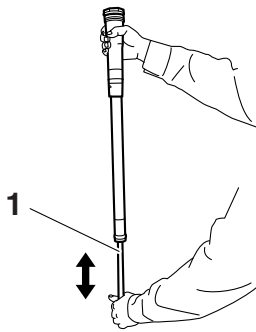

4. Measure:

- Oil level (left and right) "a"
Out of specification → Regulate.



Standard oil level
145–148 mm (5.71–5.83 in)
From top of fully stretched damper assembly.

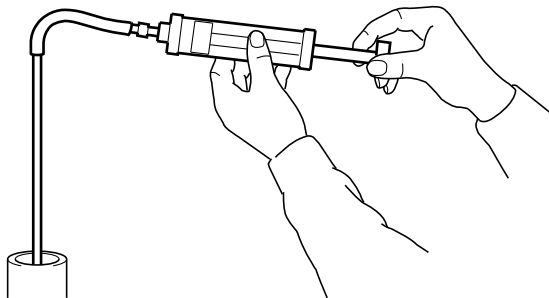
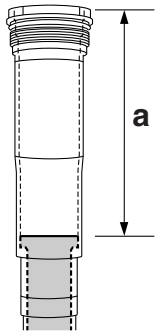

5. Tighten:

- Locknut "1"

TIP

Fully finger tighten the locknut onto the damper assembly.

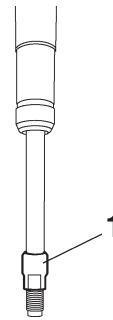

6. Loosen:

- Compression damping force adjuster "1"

TIP

- Before loosening the damping force adjuster, record the setting position.
- Unless the damping force adjuster is fully loosened, correct damping characteristic cannot be obtained after installation.

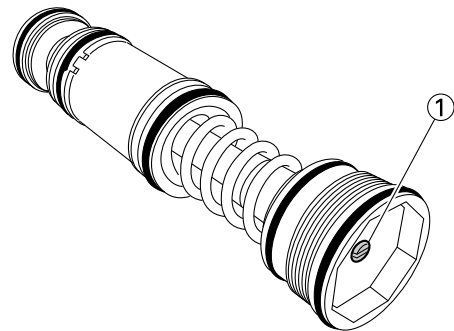

7. Install:

- Base valve "1"
(to the damper assembly "2")

TIP

First bring the damper rod pressure to a maximum. Then install the base valve while releasing the damper rod pressure.

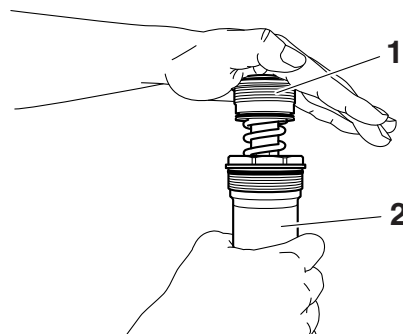

8. Check:

- Damper assembly
Not fully stretched → Repeat the steps (1) to (7).

9. Tighten:

- Base valve "1"



Base valve (front fork)
28 N·m (2.8 kgf·m, 21 lb·ft)

TIP

Hold the damper assembly with the cap bolt ring wrench "2" and use the cap bolt wrench "3" to tighten the base valve.



Cap bolt wrench
90890-01500
Cap bolt wrench
YM-01500
Cap bolt ring wrench
90890-01501
Cap bolt ring wrench
YM-01501

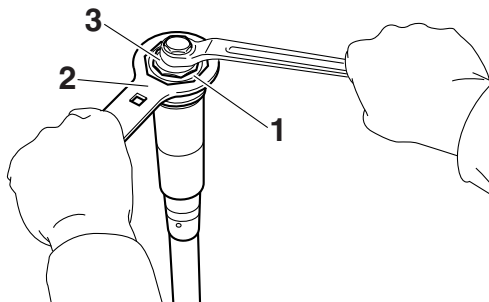

10. After filling, pump the damper assembly "1" slowly up and down more than 10 times to distribute the fork oil.

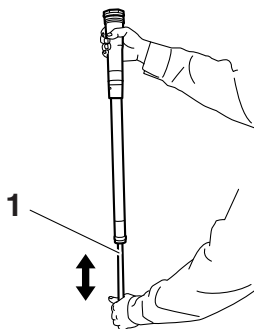

11. While protecting the damper assembly "1" with a cloth and compressing fully, allow excessive oil to overflow on the base valve side.

ECA24540

NOTICE

Take care not to damage the damper assembly.

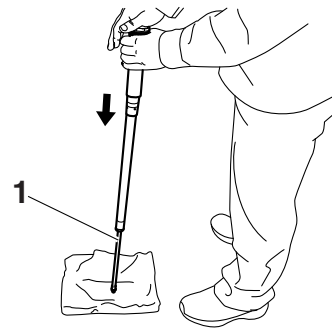

12. Allow the overflowing oil to escape at the hole "a" in the damper assembly.

TIP

The overflow measures about 10 cm³ (0.34 US oz, 0.35 Imp.oz).

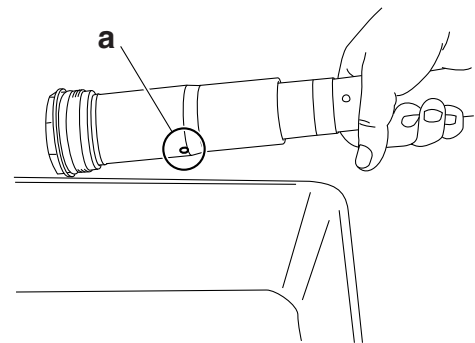

13. Check:

- Damper assembly smooth movement
- Tightness/binding/rough spots → Repeat the steps (1) to (12).

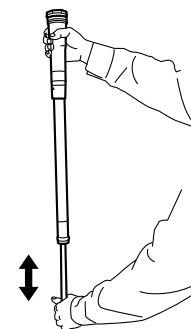

14. Install:

- Dust seal "1" **New**
- Scraper "2"
- Stopper ring "3"
- Oil seal "4" **New**
- Washer "5"
- Slide metal "6" **New**
 (to the inner tube "7")

ECA24550

NOTICE

Make sure that the numbered side of the oil seal faces bottom side.

FRONT FORK

TIP

- Apply the lithium-soap-based grease on the dust seal lip and oil seal lip.
- Apply the fork oil on the inner tube.
- Install the scraper to the inner tube as shown in the illustration.
- When installing the oil seal, use vinyl seat with fork oil applied to protect the oil seal lip.

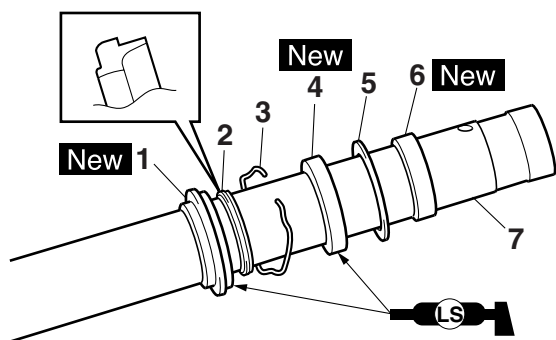

G088922

15.Install:

- Piston metal "1" **New**

TIP

Install the piston metal onto the slot on inner tube.

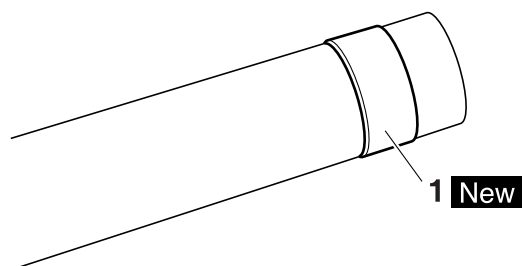

16.Install:

- Outer tube "1"
- (to the inner tube "2")

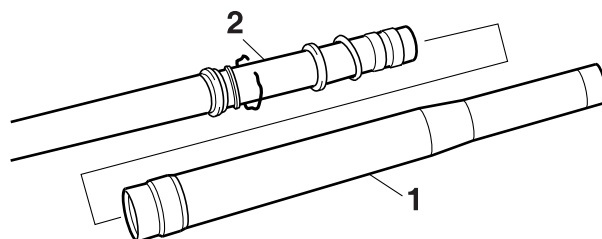

17.Install:

- Slide metal "1" **New**
- Washer "2"
- (to the outer tube)

TIP

Press the slide metal into the outer tube with fork seal driver "3".

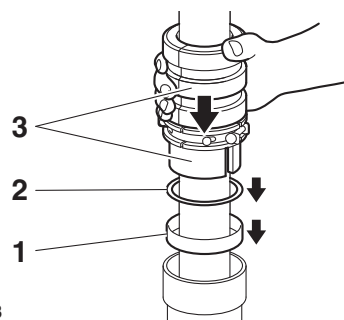
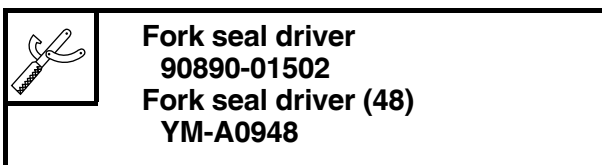

G088923

18.Install:

- Oil seal "1" **New**

TIP

Using a fork seal driver "2", press the oil seal in until the stopper ring groove fully appears.

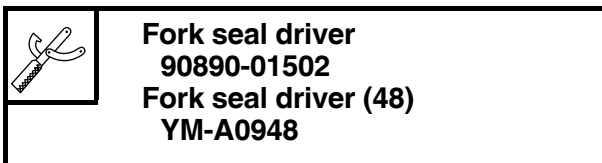

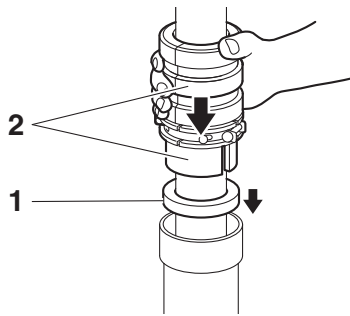

G088924

19. Install:

- Stopper ring "1"

TIP

Fit the stopper ring correctly in the groove in the outer tube.

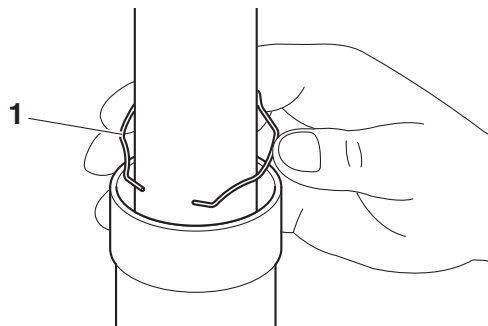

G088925

20. Install:

- Scraper "1"
- Dust seal "2" **New**

TIP

Apply lithium-soap-based grease on the inner tube.

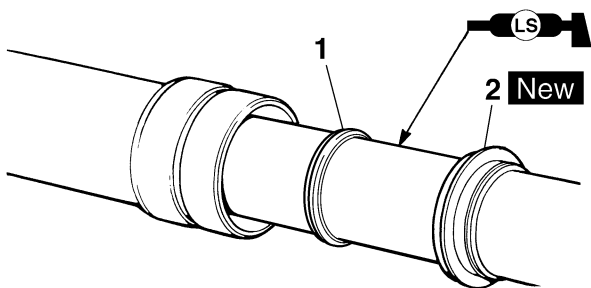

21. Check:

- Inner tube smooth movement
Tightness/binding/rough spots → Repeat the steps (14) to (20).

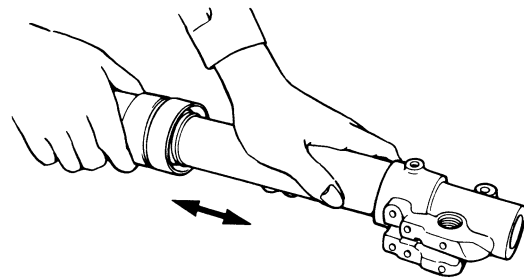

22. Measure:

- Distance "a"

Out of specification → Turn the locknut to specification.



Distance "a"
16 mm (0.63 in) or more
Between the damper assembly "1" bottom and locknut "2" bottom.

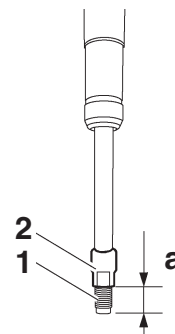

23. Install:

- Upper spring seat "1"
- Fork spring "2" (to the damper assembly "3")

TIP

Install the upper spring seat with its larger dia. end "a" facing the fork spring.

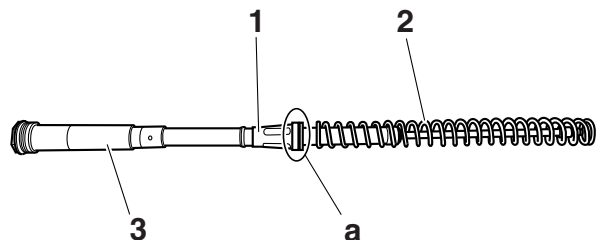

24. Install:

- Damper assembly "1" (to the inner tube "2")

ECA24560

NOTICE

Allow the damper assembly to slide slowly down the inner tube until it contacts the bottom of the inner tube. Be careful not to damage the inner tube.

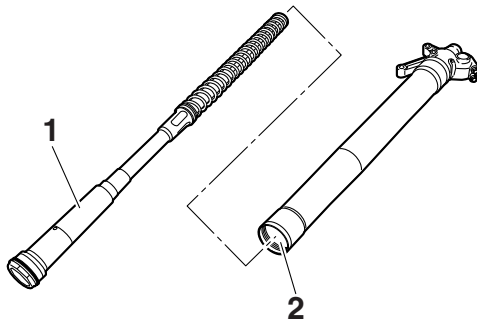

25. Loosen:

- Rebound damping force adjuster "1"

TIP

- Before loosening the damping force adjuster, record the setting position.
- Unless the damping force adjuster is fully loosened, correct damping characteristic cannot be obtained after installation.

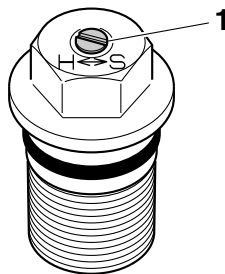

26. Install:

- Damper adjusting rod "1"
 - Copper washer "2" **New**
 - Adjuster "3"
- (to the damper assembly "4")

TIP

- While compressing the inner tube "5", set the cap bolt ring wrench "7" between the inner tube and locknut "6".
- Fully finger tighten the adjuster onto the damper assembly.



**Cap bolt ring wrench
90890-01501**
**Cap bolt ring wrench
YM-01501**

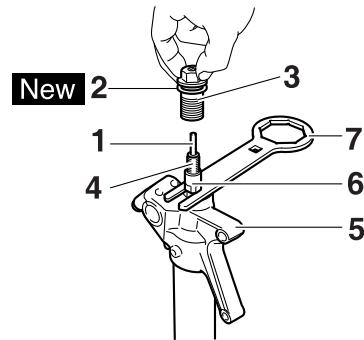

27. Measure:

- Gap "a" between the adjuster "1" and the locknut "2"
- Out of specification → Retighten and readjust the locknut.



**Gap "a" between the adjuster and the locknut
0.5–1.0 mm (0.02–0.04 in)**

TIP

If it is installed with a gap out of specification, correct damping force cannot be obtained.

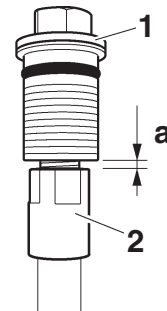

28. Tighten:

- Adjuster (damper assembly) "1"



**Adjuster (damper assembly)
29 N·m (2.9 kgf·m, 21 lb-ft)**

TIP

Hold the locknut "2" and tighten the adjuster.

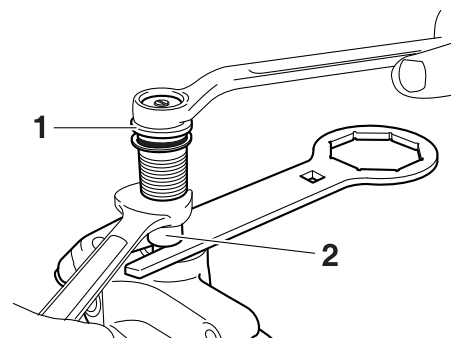

FRONT FORK

29. Install:

- Adjuster "1"
(to the inner tube)



Inner tube and adjuster
55 N·m (5.5 kgf·m, 41 lb·ft)
LOCTITE®

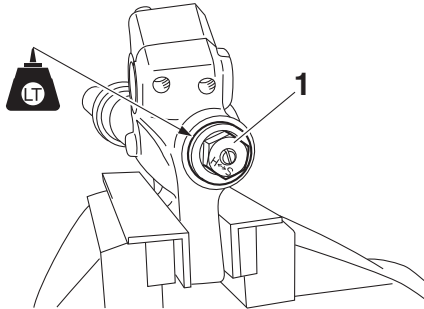

30. Fill:

- Front fork leg



Recommended oil
Yamaha Suspension Oil S1
Standard oil amount
285 cm³ (9.6 US oz, 10.1 Imp.oz)
Extent of adjustment
265–365 cm³ (9.0–12.3 US oz,
9.4–12.9 Imp.oz)

ECA24570

NOTICE

- Be sure to use the recommended oil. Other oils may have an adverse effect on front fork performance.
- When disassembling and assembling the front fork leg, do not allow any foreign material to enter the front fork.

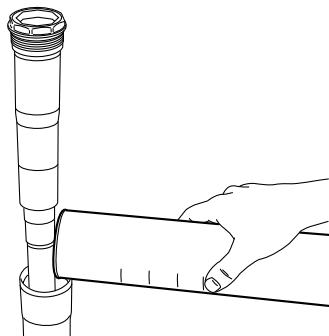

31. Install:

- Damper assembly "1"
(to the outer tube)

TIP

Temporarily tighten the damper assembly.

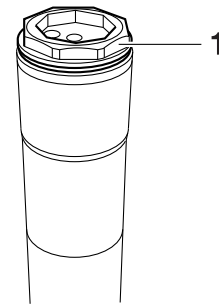

32. Install:

- Protector guide "1"

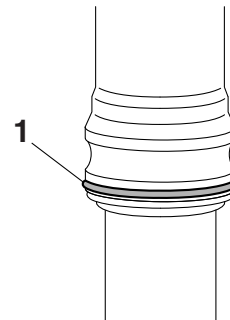

EAM30059

INSTALLING THE FRONT FORK LEGS

1. Install:

- Front fork "1"

TIP

- Temporarily tighten the lower bracket pinch bolts.
- Do not tighten the upper bracket pinch bolts yet.

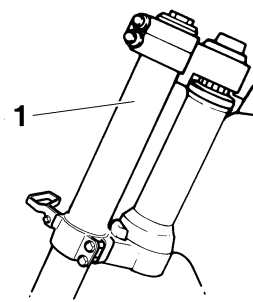

2. Tighten:

- Damper assembly "1"



Damper assembly (front fork)
30 N·m (3.0 kgf·m, 22 lb·ft)

TIP

Use the cap bolt ring wrench "2" to tighten the damper assembly.

FRONT FORK



Cap bolt ring wrench
90890-01501
Cap bolt ring wrench
YM-01501

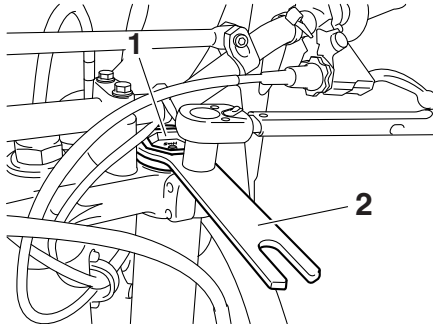

3. Adjust:

- Front fork top end "a"



Front fork top end (standard) "a"
0 mm (0.0 in)

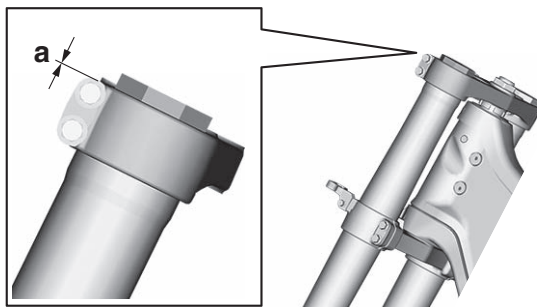

4. Tighten:

- Upper bracket pinch bolt "1"



Upper bracket pinch bolt
21 N·m (2.1 kgf·m, 15 lb·ft)

- Lower bracket pinch bolt "2"



Lower bracket pinch bolt
21 N·m (2.1 kgf·m, 15 lb·ft)

EWA19320



WARNING

Tighten the lower bracket to specified torque. If torqued too much, it may cause the front fork to malfunction.

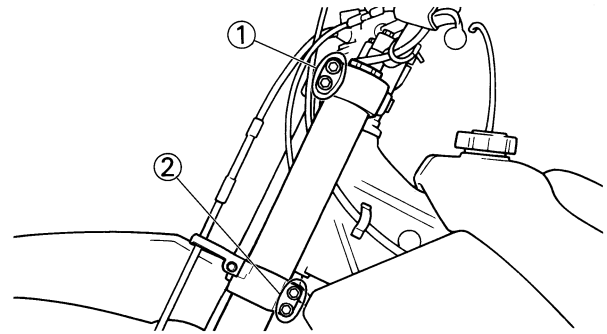

5. Install:

- Protector "1"
- Front fork protector bolt "2"



Front fork protector bolt
5 N·m (0.5 kgf·m, 3.7 lb·ft)

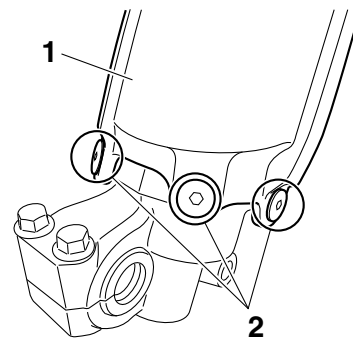

6. Adjust:

- Rebound damping force

TIP

Turn in the damping adjuster "1" finger-tight and then turn out to the originally set position.

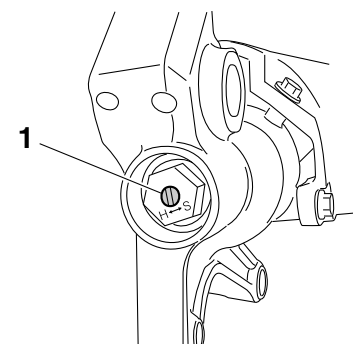

7. Adjust:

- Compression damping force

TIP

Turn in the damping adjuster "1" finger-tight and then turn out to the originally set position.

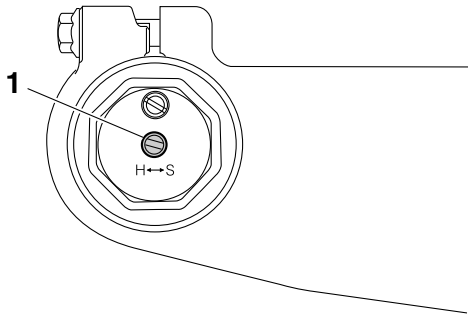

EAM20101

STEERING HEAD

EAM30060

REMOVING THE LOWER BRACKET

1. Use a maintenance stand to raise the front wheel off the ground.

EWA13120

WARNING

Securely support the vehicle so that there is no danger of it falling over.

2. Remove:
 - Ring nut "1"

TIP

Remove the ring nut with the steering nut wrench "2".



Steering nut wrench
90890-01403
Exhaust flange nut wrench
YU-A9472

EWA13730

WARNING

Securely support the lower bracket so that there is no danger of it falling.

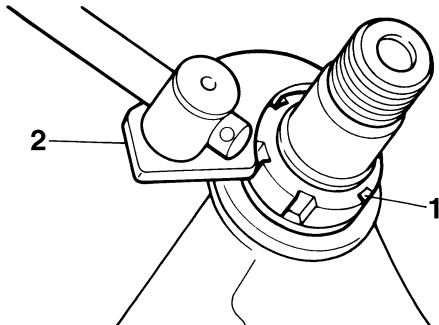

EAM30061

CHECKING THE STEERING HEAD

1. Wash with kerosene:
 - Bearing
 - Bearing race
2. Check:
 - Bearing
 - Bearing race
 Damage/pitting → Replace.
3. Replace:
 - Bearing
 - Bearing race
 - a. Remove the bearing race from the steering head pipe "1" with a long rod "2" and a hammer.
 - b. Remove the bearing race from the lower bracket "3" with a chisel "4" and a hammer.

- c. Install a new bearing race.

ECA14270

NOTICE

If the bearing race is not installed properly, the steering head pipe could be damaged.

TIP

Always replace the bearing and the bearing race as a set.

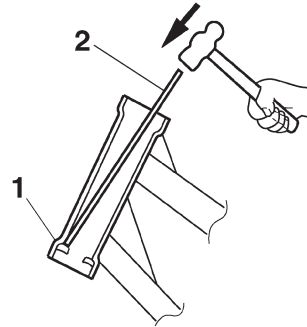

G088933

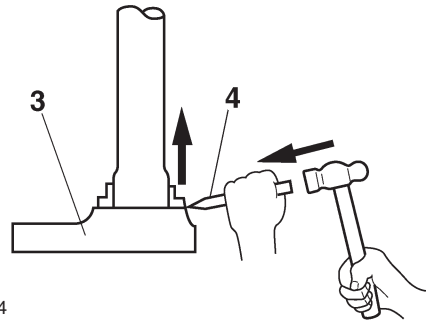

G088934

4. Check:
 - Upper bracket
 - Lower bracket
 (along with the steering stem)
Bends/cracks/damage → Replace.

EAM30062

INSTALLING THE STEERING HEAD

1. Install:
 - Lower bearing "1"

TIP

Apply the lithium-soap-based grease on the dust seal lip and bearing inner circumference.

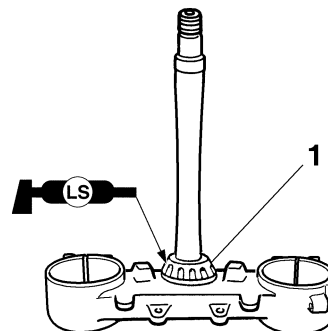

STEERING HEAD

2. Install:

- Bearing race
- Upper bearing "1"
- Bearing race cover "2"

TIP

Apply the lithium-soap-based grease on the bearing and bearing race cover lip.

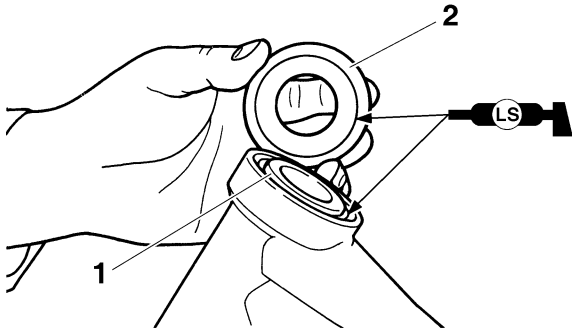

3. Install:

- Lower bracket "1"

TIP

Apply the lithium-soap-based grease on the bearing, the portion "a" and thread of the steering stem.

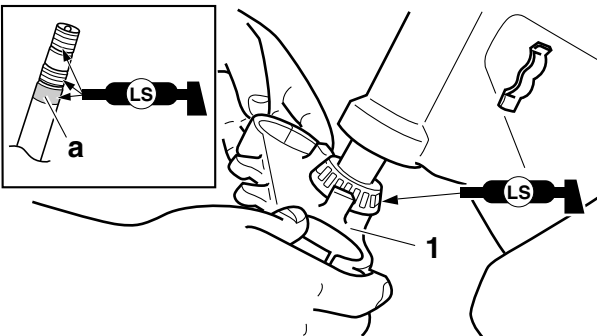

4. Install:

- Steering ring nut "1"

	<p>Steering ring nut 7 N·m (0.7 kgf·m, 5.2 lb·ft)</p>
---	--

TIP

Install the steering ring nut with its stepped side "a" facing downward.

Tighten the steering ring nut with a steering nut wrench "2".

Refer to "CHECKING AND ADJUSTING THE STEERING HEAD" on page 3-17.

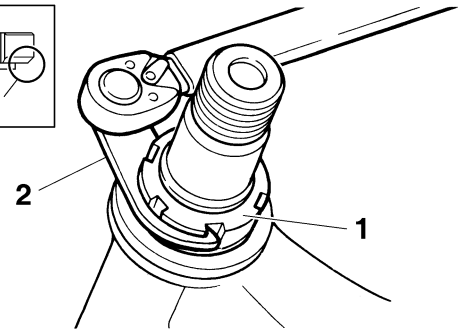
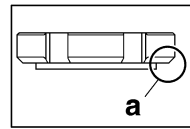

5. Check the steering stem by turning this lock to lock. If there is any binding, remove the steering stem and check the steering bearing.

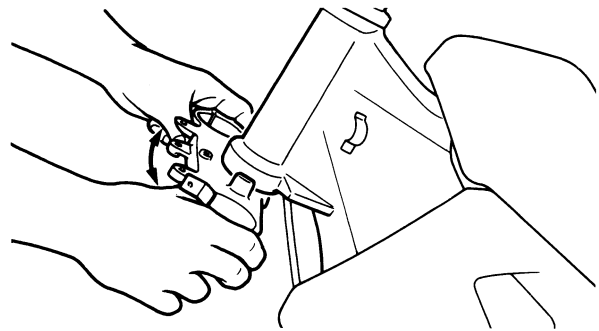

6. Install:

- Washer "1"

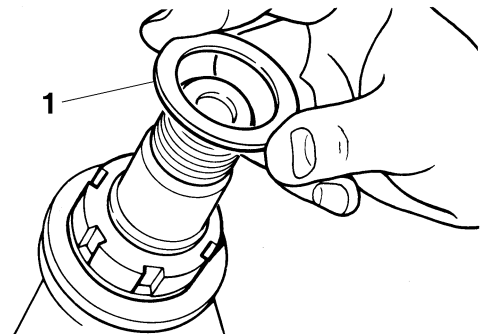

7. Install:

- Front fork "1"
- Upper bracket "2"

TIP

Temporarily tighten the lower bracket pinch bolts.

Do not tighten the upper bracket pinch bolts yet.

STEERING HEAD

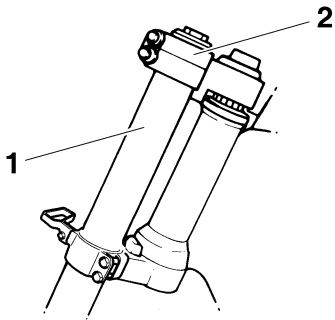

Upper bracket pinch bolt
21 N·m (2.1 kgf·m, 15 lb·ft)

- Lower bracket pinch bolt “2”



Lower bracket pinch bolt
21 N·m (2.1 kgf·m, 15 lb·ft)

EWA19330

⚠ WARNING

Tighten the lower bracket to specified torque. If torqued too much, it may cause the front fork to malfunction.

8. Install:

- Steering stem nut “1”



Steering stem nut
145 N·m (14.5 kgf·m, 107 lb·ft)

TIP

Apply the lithium-soap-based grease to the contact surface of the steering stem nut when installing.

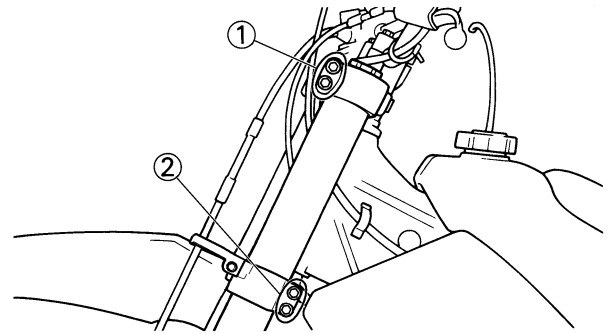
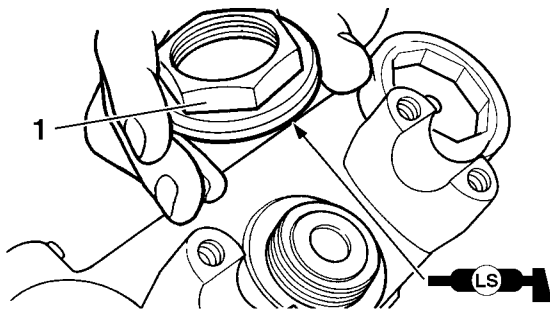

9. After tightening the nut, check the steering for smooth movement. If not, adjust the steering by loosening the steering ring nut little by little.

10. Adjust:

- Front fork top end “a”



Front fork top end (standard) “a”
0 mm (0.0 in)

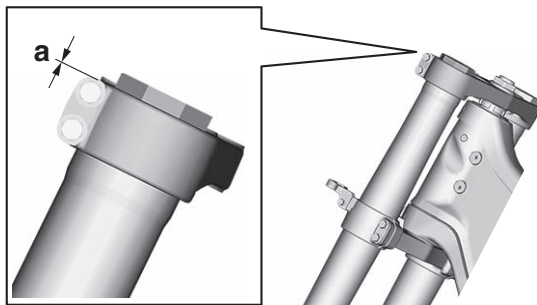

11. Tighten:

- Upper bracket pinch bolt “1”

REAR SHOCK ABSORBER ASSEMBLY

EAM20102

REAR SHOCK ABSORBER ASSEMBLY

EAM30065

REMOVING THE REAR SHOCK ABSORBER ASSEMBLY

1. Use a maintenance stand to raise the rear wheel off the ground.

EWA13120



WARNING

Securely support the vehicle so that there is no danger of it falling over.

2. Remove:
 - Rear shock absorber assembly lower bolt “1”

TIP

While removing the rear shock absorber assembly lower bolt, hold the swingarm so that it does not drop down.

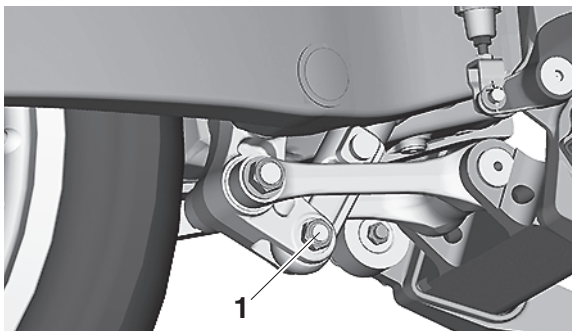

3. Remove:
 - Rear shock absorber assembly upper bolt
 - Rear shock absorber assembly

EAM30067

CHECKING THE REAR SHOCK ABSORBER ASSEMBLY

1. Check:
 - Rear shock absorber rod
Bends/damage → Replace the rear shock absorber assembly.
 - Rear shock absorber
Gas leaks/oil leaks → Replace the rear shock absorber assembly.
 - Spring
Damage/wear → Replace.
 - Spring guide
Damage/wear → Replace.
 - Bearing
Damage/wear → Replace.
 - Bolt
Bends/damage/wear → Replace.

EAM20103

SWINGARM

EAM30071

REMOVING THE SWINGARM

1. Use a maintenance stand to raise the rear wheel off the ground.

EWA13120



Securely support the vehicle so that there is no danger of it falling over.

2. Measure:
 - Swingarm side play
 - Swingarm vertical movement
 - a. Measure the tightening torque of the pivot shaft nut.



**Pivot shaft nut
85 N·m (8.5 kgf·m, 63 lb·ft)**

- b. Check the swingarm side play "A" by moving the swingarm from side to side. If the swingarm has side-to-side play, check the bushings, the bearings and the collars.
- c. Check the swingarm vertical movement "B" by moving the swingarm up and down. If swingarm vertical movement is not smooth or if there is binding, check the bushings, the bearings and the collars.

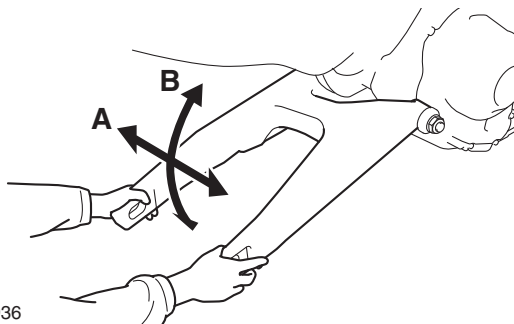

G088936

EAM20104

CHAIN DRIVE

EAM30075

REMOVING THE DRIVE CHAIN

- Stand the vehicle on a level surface.

EWA13120

WARNING

Securely support the vehicle so that there is no danger of it falling over.

TIP

Place the vehicle on a maintenance stand so that the rear wheel is elevated.

- Remove:

- Drive chain

TIP

Cut the drive chain with the drive chain cut & rivet tool. (Use goods on the market.)

EAM30076

CHECKING THE DRIVE CHAIN

- Measure:

- 15-link section of the drive chain
Out of specification → Replace the drive chain.



**15-link length limit
239.3 mm (9.42 in)**

- Measure the length "a" between the inner sides of the pins and the length "b" between the outer sides of the pins on a 15-link section of the drive chain as shown in the illustration.

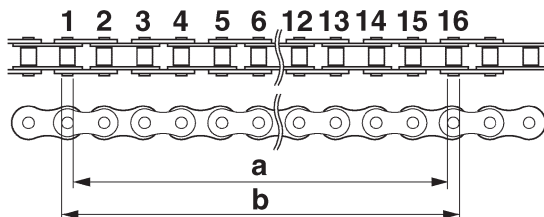

G088937

- Calculate the length "c" of the 15-link section of the drive chain using the following formula.

Drive chain 15-link section length "c" = (length "a" between pin inner sides + length "b" between pin outer sides)/2

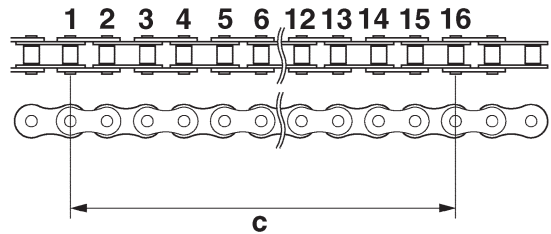

G088938

TIP

- When measuring a 15-link section of the drive chain, make sure that the drive chain is taut.
- Perform this procedure 2–3 times, at a different location each time.

- Check:

- Drive chain
Stiffness → Clean, lubricate, or replace.

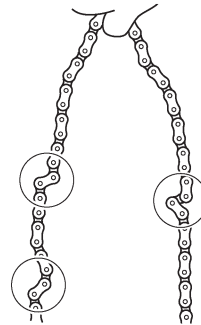

G088939

- Clean:

- Drive chain
 - Wipe the drive chain with a clean cloth.
 - Put the drive chain in kerosene and remove any remaining dirt.
 - Remove the drive chain from the kerosene and completely dry it.

ECA19090

NOTICE

- This vehicle has a drive chain with small rubber O-rings "1" between the drive chain side plates. Never use high-pressure water or air, steam, gasoline, certain solvents (e.g., benzene), or a coarse brush to clean the drive chain. High-pressure methods could force dirt or water into the drive chain's internals, and solvents will deteriorate the O-rings. A coarse brush can also damage the O-rings. Therefore, use only kerosene to clean the drive chain.
- Do not soak the drive chain in kerosene for more than ten minutes, otherwise the O-rings can be damaged.

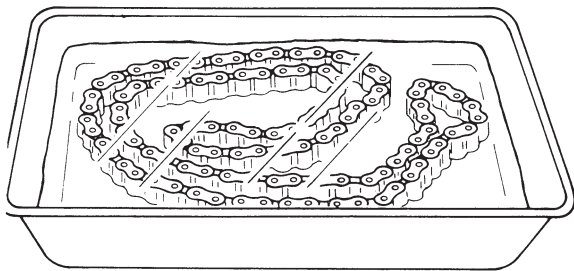

G088940

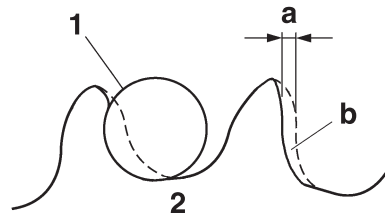

G088904

b. Correct

1. Drive chain roller
2. Drive sprocket

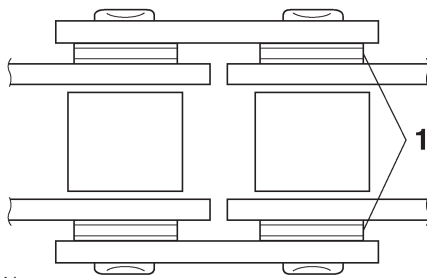

G088941

4. Check:

- O-ring "1"
Damage → Replace the drive chain.
- Drive chain roller "2"
Damage/wear → Replace the drive chain.
- Drive chain side plate "3"
Damage/wear → Replace the drive chain.

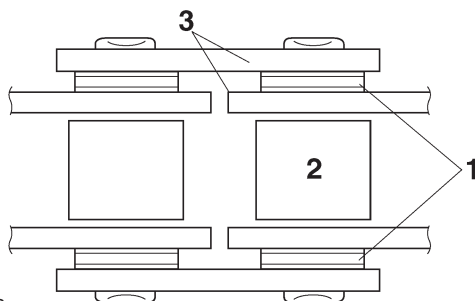

G088943

5. Lubricate:

- Drive chain



EAM30077

CHECKING THE DRIVE SPROCKET

1. Check:

- Drive sprocket
More than 1/4 tooth wear "a" → Replace the drive sprocket and the rear wheel sprocket as a set.
Bent tooth → Replace the drive sprocket and the rear wheel sprocket as a set.

EAM30078

CHECKING THE REAR WHEEL SPROCKET
Refer to "CHECKING AND REPLACING THE REAR WHEEL SPROCKET" on page 4-3.

EAM30079

INSTALLING THE DRIVE CHAIN

1. Install:

- Drive chain

ECA17410

NOTICE

Be sure to put on safety goggles when working.

TIP

Install the master link with the drive chain cut & rivet tool. (Use goods on the market.)

- a. When press fitting the master link plate "1", make sure the space "a" between the end of the connecting pin "2" and the master link plate is 1.2–1.4 mm (0.05–0.06 in).

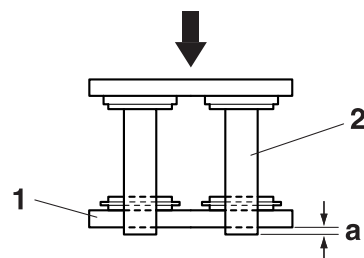

- b. After riveting, make sure the diameter between the edges "b" of the connecting pin "2" is 5.5–5.8 mm (0.22–0.23 in).

ECA24590

NOTICE

A drive chain that is too tight will overload the engine and other vital parts, and one that is too loose can skip and damage the swing-arm or cause an accident. Therefore, keep the drive chain slack within the specified limits.

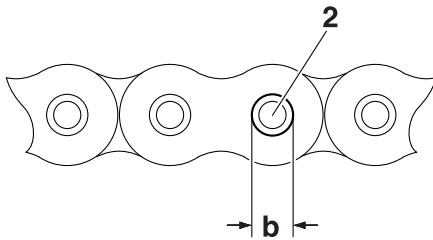

- c. After riveting, make sure the space “c”, which is inside of the master link “3” and inside of the master link plate “1”, is 12.1–12.3 mm (0.476–0.484 in).

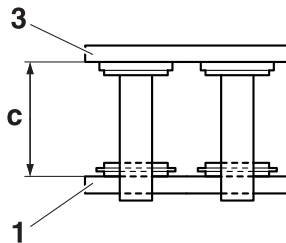

2. Lubricate:
- Drive chain



3. Install:
- Drive sprocket
 - Lock washer **New**
 - Drive sprocket nut



ECA14300

NOTICE

Never install a new drive chain onto worn drive chain sprockets; this will dramatically shorten the drive chain’s life.

4. Adjust:
- Drive chain slack
Refer to “DRIVE CHAIN SLACK” on page 3-16.



ENGINE

CLUTCH	5-1
REMOVING THE CLUTCH	5-1
CHECKING THE FRICTION PLATES	5-1
CHECKING THE CLUTCH PLATES	5-1
CHECKING THE CLUTCH SPRINGS	5-1
CHECKING THE CLUTCH HOUSING	5-1
CHECKING THE CLUTCH BOSS	5-2
CHECKING THE PRESSURE PLATE	5-2
CHECKING THE PUSH LEVER SHAFT	5-2
CHECKING THE PUSH RODS	5-2
CHECKING THE PRIMARY DRIVE GEAR	5-2
CHECKING THE PRIMARY DRIVEN GEAR	5-2
INSTALLING THE CLUTCH	5-2

EAM20111

CLUTCH

EAM30108

REMOVING THE CLUTCH

- Remove:
 - Clutch boss nut "1"
 - Lock washer
 - Clutch boss "2"

TIP

- While holding the clutch boss with the clutch holder "3", loosen the clutch boss nut.
- Do not use an impact wrench for removing the clutch boss nut.



Clutch holder
90890-04199
Universal clutch holder
YM-91042

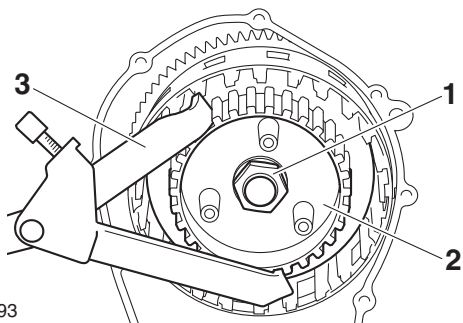

G088993

EAM30109

CHECKING THE FRICTION PLATES

- Check:
 - Friction plate
 Damage/wear → Replace the friction plates as a set.
- Measure:
 - Friction plate thickness
 Out of specification → Replace the friction plates as a set.

TIP

Measure it at four points on the friction plate.



Friction plate 1 thickness
2.92–3.08 mm (0.115–0.121 in)
Wear limit
2.82 mm (0.111 in)
Friction plate 2 thickness
2.90–3.10 mm (0.114–0.122 in)
Wear limit
2.80 mm (0.110 in)

EAM30110

CHECKING THE CLUTCH PLATES

- Check:
 - Clutch plate
 Damage → Replace the clutch plates as a set.
- Measure:
 - Clutch plate warpage
 (with a surface plate and thickness gauge)
 Out of specification → Replace the clutch plates as a set.



Thickness gauge
90890-03268
Feeler gauge set
YU-26900-9



Clutch plate thickness
1.50–1.70 mm (0.059–0.067 in)
Warpage limit
0.20 mm (0.008 in)

EAM30111

CHECKING THE CLUTCH SPRINGS

- Check:
 - Clutch spring
 Damage → Replace the clutch springs as a set.
- Measure:
 - Clutch spring free length
 Out of specification → Replace the clutch springs as a set.



Clutch spring free length
44.00 mm (1.73 in)
Clutch spring free length limit
41.80 mm (1.65 in)

EAM30112

CHECKING THE CLUTCH HOUSING

- Check:
 - Clutch housing dogs
 Damage/pitting/wear → Deburr the clutch housing dogs or replace the clutch housing.

TIP

Pitting on the clutch housing dogs will cause erratic clutch operation.

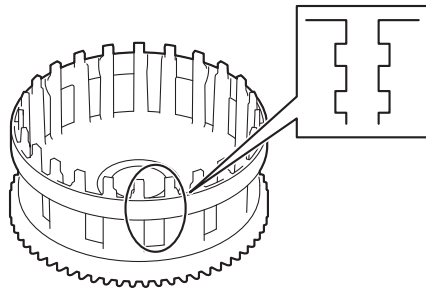

G088994

EAM30113

CHECKING THE CLUTCH BOSS

1. Check:

- Clutch boss splines
Damage/pitting/wear → Replace the clutch boss.

TIP

Pitting on the clutch boss splines will cause erratic clutch operation.

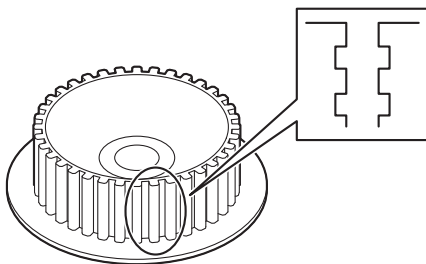

G088995

EAM30114

CHECKING THE PRESSURE PLATE

1. Check:

- Pressure plate
Crack/damage → Replace.

EAM30115

CHECKING THE PUSH LEVER SHAFT

1. Check:

- Push lever shaft
Wear/damage → Replace.

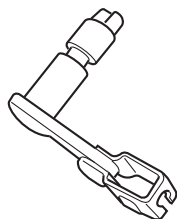

EAM30484

CHECKING THE PUSH RODS

1. Check:

- Push rod 1 "1"
 - Bearing "2"
 - Washer "3"
 - Push rod 2 "4"
- Cracks/damage/wear → Replace.

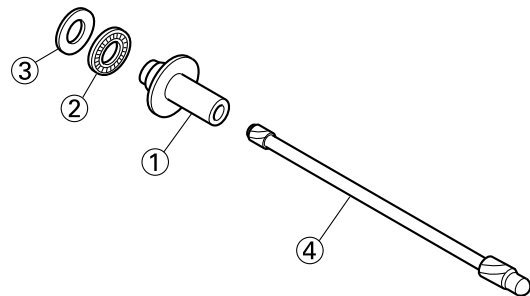

2. Measure:

- Push rod 2 bending limit
Out of specification → Replace.



**Push rod bending limit
0.30 mm (0.012 in)**

EAM30117

CHECKING THE PRIMARY DRIVE GEAR

1. Check:

- Primary drive gear
Damage/wear → Replace the primary drive and primary driven gears as a set.
Excessive noise during operation → Replace the primary drive and primary driven gears as a set.

2. Check:

- Primary-drive-gear-to-primary-driven-gear free play
Free play exists → Replace the primary drive and primary driven gears as a set.

EAM30118

CHECKING THE PRIMARY DRIVEN GEAR

1. Check:

- Primary driven gear
Damage/wear → Replace the primary drive and primary driven gears as a set.
Excessive noise during operation → Replace the primary drive and primary driven gears as a set.

EAM30121

INSTALLING THE CLUTCH

1. Install:

- Bearing "1"
- Oil seal "2" **New**

- Push lever shaft “3”
- Copper washer “4” **New**
- Push lever shaft bolt “5”



Push lever shaft bolt
6 N·m (0.6 kgf·m, 4.4 lb-ft)

TIP

Apply the lithium-soap-based grease on the oil seal lip.

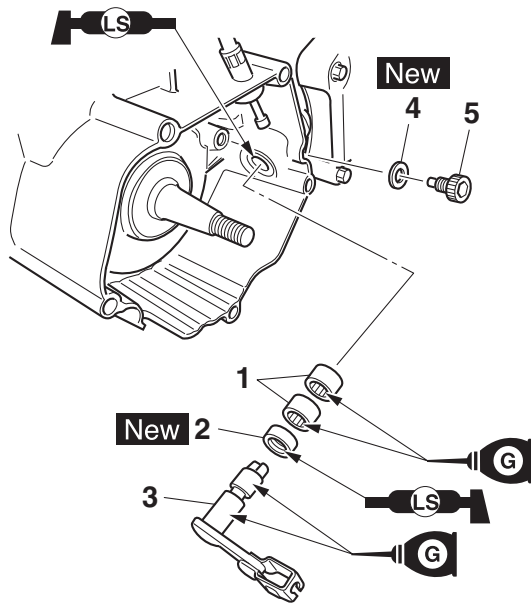

2. Install:

- Thrust washer [D = \varnothing 42 mm (1.65 in)] “1”
- Spacer “2”
- Bearing “3”
- Primary driven gear “4”

TIP

Apply the transmission oil on the bearing, spacer and primary driven gear inner circumference.

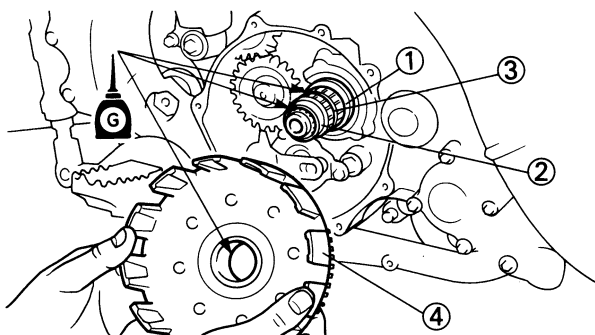

3. Install:

- Thrust washer [D = \varnothing 44 mm (1.73 in)] “1”
- Clutch boss “2”

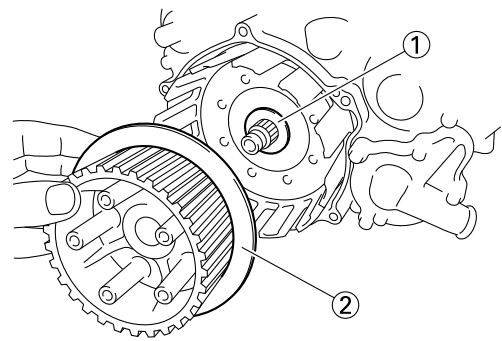

4. Install:

- Lock washer “1” **New**
- Clutch boss nut “2”



Clutch boss nut
75 N·m (7.5 kgf·m, 55 lb-ft)

TIP

Use the clutch holder “3” to hold the clutch boss.



Clutch holder
90890-04199
Universal clutch holder
YM-91042

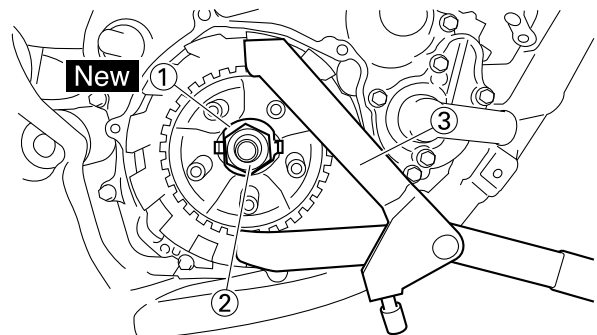

5. Bend the lock washer “1” tab.

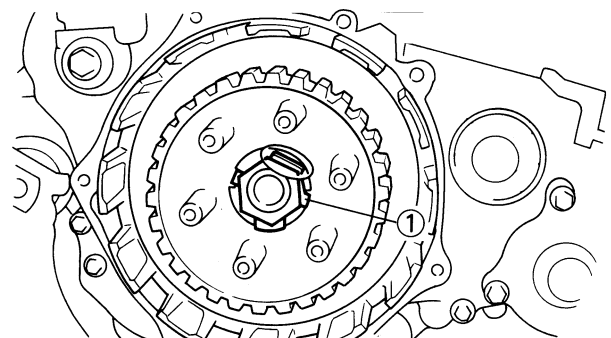

6. Install:

- Friction plate “1”
- Clutch plate “2”

TIP

Install the clutch plates and friction plates alternately on the clutch boss, starting with a friction

plate and ending with a friction plate.

- Install the friction plates that have black paint on the outer circumference of the pawls at the innermost and outermost positions, respectively.
- Apply the transmission oil on the friction plates and clutch plates.

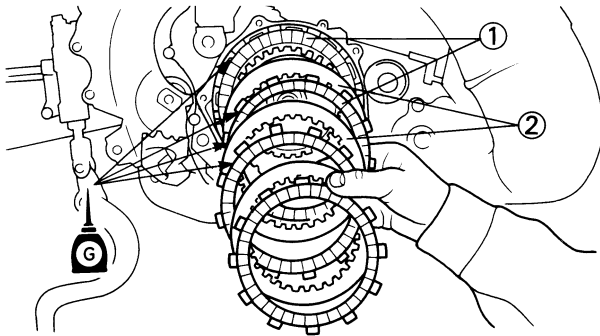

7. Install:
- Bearing "1"
 - Washer "2"
 - Circlip "3" **New** (to the push rod 1 "4")

TIP
Apply the transmission oil on the bearing, washer and push rod 1.

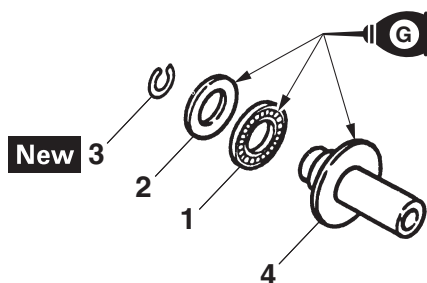

8. Install:
- Push rod 2 "1"
 - Push rod 1 "2"

TIP
• Apply the transmission oil on the ends of the push rod 2.
• Install the push rod 2 with its smaller end "a" toward you.

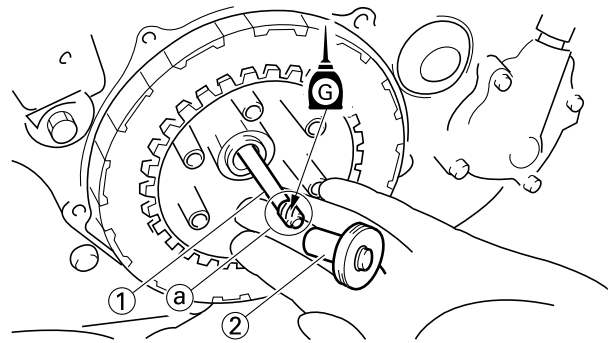

9. Install:
- Pressure plate "1"

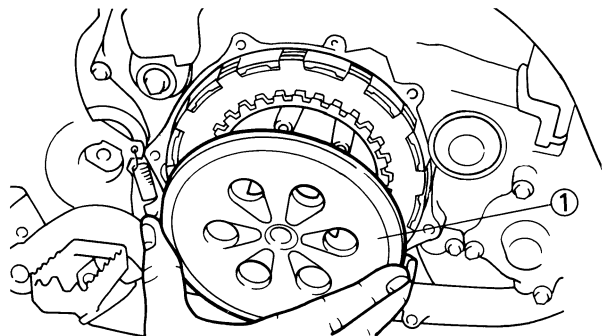

10. Install:
- Clutch spring
 - Clutch spring bolt

	Clutch spring bolt 10 N·m (1.0 kgf·m, 7.4 lb·ft)
---	--

TIP
Tighten the bolts in stage, using a crisscross pattern.

11. Install:
- O-ring "1" **New** (to the clutch cover)

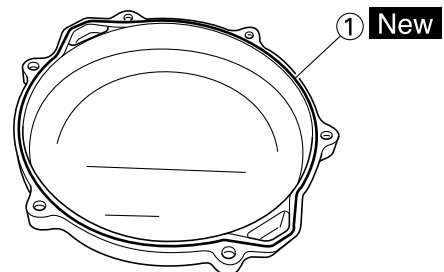

12. Install:
- Clutch cover
 - Clutch cover bolt

	Clutch cover bolt 10 N·m (1.0 kgf·m, 7.4 lb·ft)
---	---

TIP

Tighten the bolts in stage, using a crisscross pattern.

13. Install:

- O-ring "1" **New**
- Clutch cable "2"

TIP

Apply the lithium-soap-based grease on the O-ring.

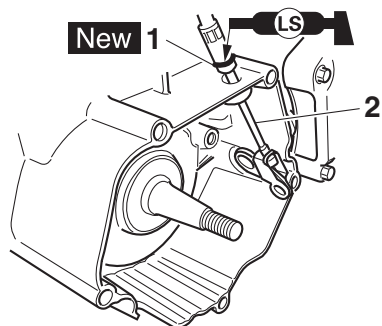

ELECTRICAL SYSTEM

WIRING DIAGRAM.....	6-1
COLOR CODE	6-1

EAM20195

WIRING DIAGRAM

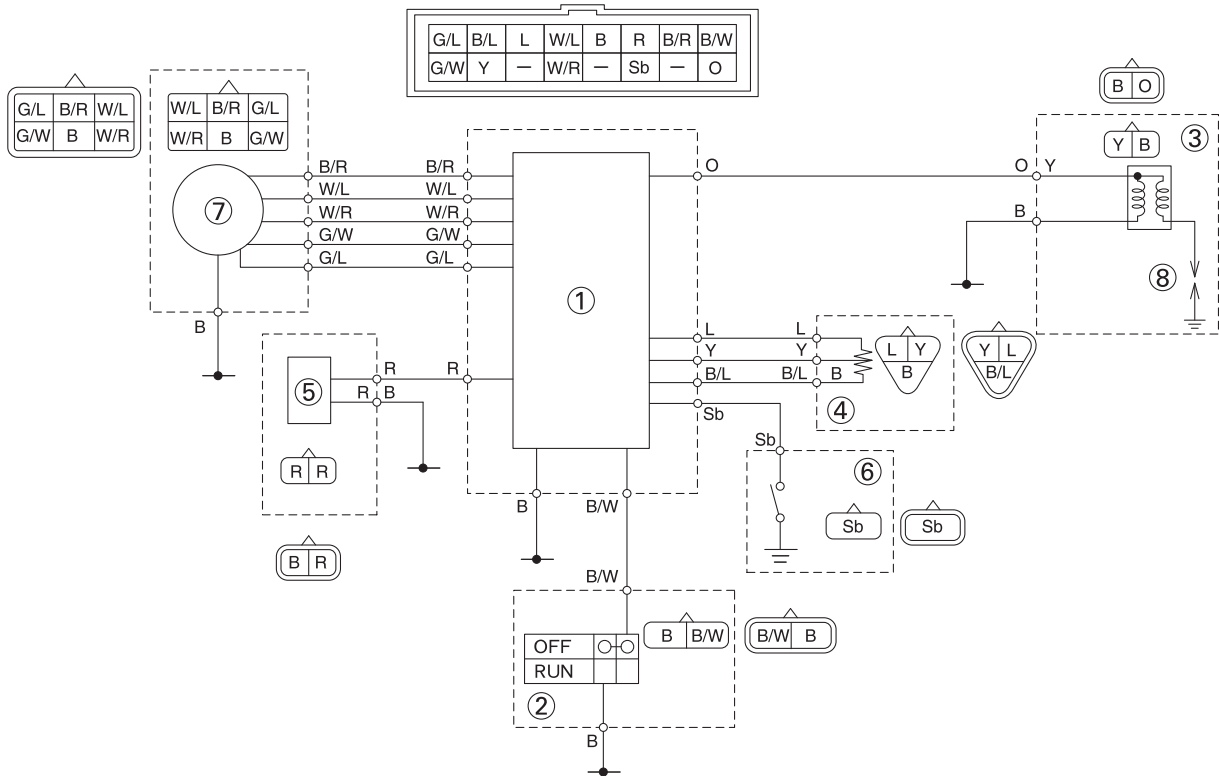

1. CDI unit
2. Engine stop switch
3. Ignition coil
4. Throttle position sensor
5. Solenoid valve
6. Neutral switch
7. CDI magneto
8. Spark plug

EAM30608

COLOR CODE

B	Black
L	Blue
O	Orange
R	Red
Sb	Sky blue
Y	Yellow
B/L	Black/Blue
B/R	Black/Red
B/W	Black/White
G/L	Green/Blue
G/W	Green/White
W/L	White/Blue
W/R	White/Red

TROUBLESHOOTING

TROUBLESHOOTING	7-1
GENERAL INFORMATION	7-1
TROUBLESHOOTING OF ENGINE.....	7-1
TROUBLESHOOTING OF CLUTCH.....	7-6
TROUBLESHOOTING OF TRANSMISSION	7-7
TROUBLESHOOTING OF COOLING SYSTEM	7-8
TROUBLESHOOTING OF BRAKE	7-9
TROUBLESHOOTING OF SUSPENSION.....	7-9
TROUBLESHOOTING OF STEERING/HANDLING	7-11

EAM20148

TROUBLESHOOTING

EAM30309

GENERAL INFORMATION

TIP

- Troubleshooting information provided here does not cover all the trouble symptoms, possible causes, and remedial actions. Some items may not apply depending on the model. Use this information as a guide and quick reference matrix when performing basic troubleshooting. Refer to the each chapter for detailed information on checking, adjustment, and replacement.
- The following guide for troubleshooting represent quick and easy procedures for checking these vital systems yourself. However, should your motorcycle require any repair, take it to a Yamaha dealer, whose skilled technicians have the necessary tools, experience, and know-how to service the motorcycle properly.

EAM30612

TROUBLESHOOTING OF ENGINE

Engine will not start or is difficult to start, but it cranks.

Symptom	Possible cause	Actions
Spark plug does not produce a spark	Have a Yamaha dealer check the electrical system.	
Fuel not supplied	Empty fuel tank	Fill the fuel tank with fuel.
	Clogged fuel tank cap breather hole	Clean the fuel tank cap.
	Clogged or damaged fuel hose	Clean, repair, or replace the fuel hose.
	Fuel leakage	Check the fuel passage. Repair or replace as necessary.
	Clogged fuel cock strainer	Clean or replace the fuel cock strainer.
	Clogged fuel cock	Clean or replace the fuel cock.
	Cracked, damaged or worn fuel cock	Replace the fuel cock.
	Clogged carburetor fuel passage	Clean the carburetor.
	Clogged needle valve or needle valve seat	Clean the needle valve or needle valve seat.
	Damaged float	Replace the float.
	Clogged pilot jet	Clean the pilot jet.
	Clogged starter jet	Clean the starter jet.
	Bent or damaged starter plunger	Replace the starter plunger.
	Incorrectly adjusted starter cable	Adjust the starter cable.
—	Water or foreign material in fuel, degraded fuel	Change fuel.

TROUBLESHOOTING

Symptom	Possible cause	Actions
Compression pressure is low	—	Measure the compression pressure.
	Loose spark plug	Tighten the spark plugs to the specified torque.
	Loose cylinder head or cylinder	Tighten bolts or nuts on cylinder head and cylinder to the specified torque.
	Damaged cylinder head gasket	Replace the cylinder head gasket.
	Worn, damaged, or stuck piston ring	Replace the piston and piston rings as a set.
	Seized or damaged piston	Replace the piston and piston rings as a set.
	Worn or damaged cylinder bore	Replace the cylinder, piston, and piston rings as a set.

Incorrect idling speed or mid-to-high speed

Symptom	Possible cause	Actions
Spark plug does not produce a spark	Incorrect spark plug gap	Adjust the spark plug gap.
	Worn or damaged spark plug	Replace the spark plug.
	Defective spark plug cap	Replace the spark plug cap.
	Defective ignition coil	Replace the ignition coil.
	CDI unit failure	Replace the CDI unit.
Fuel not supplied	Fuel leakage	Check the fuel passage. Repair or replace as necessary.
	Clogged carburetor fuel passage	Clean the carburetor.
	Clogged needle valve or needle valve seat	Clean the needle valve or needle valve seat.
	Damaged float	Replace the float.
—	Water or foreign material in fuel, degraded fuel	Change fuel.
	Clogged carburetor air passage	Clean the carburetor.
	Incorrectly adjusted throttle cable	Adjust the throttle grip free play.
	Incorrectly adjusted idling speed (throttle stop screw)	Adjust the throttle stop screw.
	Incorrectly adjusted pilot screw	Adjust the pilot screw.
	Incorrectly adjusted pilot air screw	Adjust the pilot air screw.
	Clogged pilot jet	Clean the pilot jet.
	Loose pilot jet	Tighten the pilot jet to the specified torque.
	Damaged or worn needle valve seat	Replace the needle valve seat.
	Loose needle valve seat	Tighten the needle valve seat to the specified torque.

TROUBLESHOOTING

Symptom	Possible cause	Actions
	Damaged or worn needle valve	Replace the needle valve.
	Incorrect fuel level	Adjust the fuel level to the proper level.
	Bent, worn, or damaged starter plunger	Replace the starter plunger.
	Incorrectly adjusted starter cable	Adjust the starter cable.
	Clogged or damaged carburetor breather hose	Clean, repair, or replace the carburetor breather hose.
	Incorrect throttle position sensor angle	Adjust the throttle position sensor angle.
	Failed air induction system	Check the air induction system. Repair or replace faulty parts.
	Clogged vacuum hose	Clean the vacuum hose.
	Cracks and damage in vacuum hose	Replace the vacuum hose.
	Damaged carburetor joint	Replace the carburetor joint.
	Loose carburetor joint	Tighten the carburetor joint bolts to the specified torque.
	Clogged air filter element	Clean or replace the air filter element.

Incorrect mid-high speed

Symptom	Possible cause	Actions
Spark plug does not produce a spark	Incorrect spark plug gap	Adjust the spark plug gap.
	Worn or damaged spark plug	Replace the spark plug.
	Defective spark plug cap	Replace the spark plug cap.
	Defective ignition coil	Replace the ignition coil.
	CDI unit failure	Replace the CDI unit.
Fuel not supplied	Fuel leakage	Check the fuel passage. Repair or replace as necessary.
	Clogged carburetor fuel passage	Clean the carburetor.
	Clogged needle valve or needle valve seat	Clean the needle valve or needle valve seat.
	Damaged float	Replace the float.

TROUBLESHOOTING

Symptom	Possible cause	Actions
	Water or foreign material in fuel, degraded fuel	Change fuel.
	Clogged carburetor air passage	Clean the carburetor.
	Incorrectly adjusted throttle cable	Adjust the throttle grip free play.
	Improperly synchronized carburetors	Adjust synchronization of carburetors.
	Incorrectly adjusted pilot screw	Adjust the pilot screw.
	Incorrectly adjusted pilot air screw	Adjust the pilot air screw.
	Clogged pilot jet	Clean the pilot jet.
	Loose pilot jet	Tighten the pilot jet to the specified torque.
	Clogged main nozzle	Clean the main nozzle.
	Loose main nozzle	Tighten the main nozzle to the specified torque.
	Clogged main jet	Clean the main jet.
	Loose main jet	Tighten the main jet to the specified torque.
	Bent, damaged, or worn jet needle	Replace the jet needle.
	Cracks or damage in the piston valve diaphragm	Replace the piston valve diaphragm.
	Problem with piston valve movement (movement is not smooth)	Replace the piston valve.
	Damaged or worn needle valve seat	Replace the needle valve seat.
	Loose needle valve seat	Tighten the needle valve seat to the specified torque.
	Damaged or worn needle valve	Replace the needle valve.
	Incorrect fuel level	Adjust the fuel level to the proper level.
	Bent, worn, or damaged starter plunger	Replace the starter plunger.
	Incorrectly adjusted starter cable	Adjust the starter cable.
	Clogged or damaged carburetor breather hose	Clean, repair, or replace the carburetor breather hose.
	Incorrect throttle position sensor angle	Adjust the throttle position sensor angle.

TROUBLESHOOTING

Symptom	Possible cause	Actions
—	Failed air induction system	Check the air induction system. Repair or replace faulty parts.
	Clogged vacuum hose	Clean the vacuum hose.
	Cracks and damage in vacuum hose	Replace the vacuum hose.
	Damaged carburetor joint	Replace the carburetor joint.
	Loose carburetor joint	Tighten the carburetor joint bolts to the specified torque.
	Clogged air filter element	Clean or replace the air filter element.

Excessive noise from engine

Symptom	Possible cause	Actions
Noise heard from around piston	Worn or damaged piston ring	Replace the piston and piston rings as a set.
	Worn or damaged piston	Replace the piston and piston rings as a set.
	Worn piston (piston pin hole)	Replace the piston and piston pin as a set.
	Worn or damaged piston pin	Replace the piston pin.
	Worn or damaged cylinder bore	Replace the cylinder, piston, and piston rings as a set.
	Carbon buildup in piston head and combustion chamber	Clean the piston head and combustion chamber.
Noise heard from around crankshaft	Worn or damaged crankshaft journal or crank pin	Replace the crankshaft.
	Worn or damaged big end bearing	Replace the big end bearing.
	Worn or damaged crankshaft journal bearing	Replace the crankshaft journal bearing.
	Worn or damaged balancer shaft journal bearing	Replace the balancer shaft journal bearing.

TROUBLESHOOTING

EAM30510

TROUBLESHOOTING OF CLUTCH

Manual clutch

Symptom	Possible cause	Actions
Clutch slippage	Improperly assembled clutch	Reassemble the clutch.
	Improperly adjusted clutch cable	Adjust the clutch lever free play.
	Loose clutch spring	Tighten the clutch spring bolts to the specified torque.
	Fatigued clutch spring	Replace the clutch springs as a set.
	Warped pressure plate	Replace the pressure plate.
	Worn friction plate	Replace the friction plates as a set.
	Warped or worn clutch plate	Replace the clutch plates as a set.
	Incorrect oil level	Adjust the engine oil level to the specified level.
	Incorrect oil viscosity (low)	Change to recommended engine oil.
	Deteriorated oil	Change to recommended engine oil.
Clutch drags	Faulty clutch spring	Replace the clutch springs as a set.
	Warped pressure plate	Replace the pressure plate.
	Swollen friction plate	Replace the friction plates as a set.
	Warped clutch plate	Replace the clutch plates as a set.
	Bent pull rod (outer pull type)	Replace the pull rod.
	Worn pull rod tooth (outer pull type)	Replace the pull rod and pull lever shaft as a set.
	Bent push rod (inner push type)	Replace the push rod.
	Damaged or worn clutch boss	Replace the clutch boss.
	Seized clutch housing bushing	Replace the clutch housing.
	Improperly installed pull lever	Align the match mark on the pull lever before installation.
	Incorrect oil level	Adjust the engine oil level to the specified level.
	Incorrect oil viscosity (high)	Change to recommended engine oil.
	Deteriorated oil	Change to recommended engine oil.

TROUBLESHOOTING

Symptom	Possible cause	Actions
Clutch noise	Damaged or worn primary driven gear	Replace the primary drive gear or crankshaft, and the clutch housing as a set.
	Loose clutch boss nut	Tighten the clutch boss nut to the specified torque.
	Fatigued clutch damper	Replace the clutch housing.
	Worn clutch housing bearing	Replace the clutch housing bearing.
	Worn pressure plate bearing	Replace the pressure plate bearing.

EAM30511

TROUBLESHOOTING OF TRANSMISSION

Symptom	Possible cause	Actions
Difficult or impossible to shift transmission gear	Clutch drags	Refer to "Clutch drags".
	Improperly adjusted shift rod	Adjust the shift rod installation length.
	Bent shift shaft	Replace the shift shaft.
	Foreign object in a shift drum groove	Remove foreign object from shift drum groove.
	Damaged shift drum	Replace the shift drum.
	Seized shift fork	Replace the shift fork and shift fork guide bar as a set.
	Bent shift fork guide bar	Replace the shift fork guide bar.
	Foreign object between transmission gears	Remove foreign object from transmission gears.
	Seized transmission gear	Replace the seized gear and the axle as a set.
	Improperly assembled transmission	Reassemble the transmission axle assembly.
Jumps out of gear	Incorrect shift pedal position	Adjust the shift pedal position.
	Improperly returned stopper lever	Replace the stopper lever spring.
	Bent or worn shift fork	Replace the shift fork.
	Shift drum incorrect axial play	Replace the shift drum.
	Worn shift drum groove	Replace the shift drum.
	Worn transmission gear dog	Replace the transmission gear.
Transmission noise	Damaged or worn transmission gear	Replace the transmission gear.
	Worn main axle spline	Replace the main axle.
	Worn drive axle spline	Replace the drive axle.
	Worn bearing	Replace the bearing.

TROUBLESHOOTING

EAM30512

TROUBLESHOOTING OF COOLING SYSTEM

Symptom	Possible cause	Actions
Overheating	Carbon buildup in piston head and combustion chamber	Clean the piston head and combustion chamber.
	Clogged engine cooling water passages	Check and clean the engine cooling water passages.
	Damaged or leaking radiator	Replace the radiator.
	Faulty radiator cap	Replace the radiator cap.
	Clogged radiator fin	Clean the radiator fin.
	Bent or damaged radiator fin	Repair the radiator fin or replace the radiator.
	Damaged or faulty water pump	Replace the water pump.
	Damaged hoses or pipes	Replace the hose or pipe.
	Improperly connected hoses or pipes	Connect the hoses and pipes properly.
	Clogged air filter element	Clean or replace the air filter element.
	Brake drags	Check the brake system and repair or replace faulty parts as necessary.
	Incorrect spark plug gap	Adjust to the specified spark plug gap.
Incorrect spark plug heat range	Replace the spark plug with the one of the specified type.	
Noise from water pump	Contact between the water pump housing cover and impeller	Disassemble the water pump and replace faulty parts.
	Worn water pump housing bearing	Replace the water pump housing bearing.

TROUBLESHOOTING

EAM30513

TROUBLESHOOTING OF BRAKE

Symptom	Possible cause	Actions
Poor performance of disc brake	Worn brake pad	Replace the brake pads as a set.
	Worn or deflected brake disc	Replace the brake disc.
	Air in hydraulic brake system	Bleed the hydraulic brake system.
	Brake fluid leakage	Check the hydraulic brake system and repair or replace faulty parts as necessary.
	Incorrect brake fluid level (low)	Add brake fluid to the specified level.
	Stuck brake caliper piston	Replace the caliper piston seal.
	Stuck brake caliper and slide pin	Lubricate the caliper slide pin.
	Loose union bolt	Tighten the union bolt to the specified torque.
	Damaged brake hose and brake pipe	Replace the brake hose and brake pipe.
	Oil or grease on the brake disc or brake pad	Clean the brake disc or brake pad.
	Insufficient lubrication of brake lever or brake pedal pivot	Lubricate the brake lever or brake pedal pivot.

EAM30514

TROUBLESHOOTING OF SUSPENSION

Symptom	Possible cause	Actions
Front fork is hard	Bent or damaged inner tube	Replace the inner tube.
	Bent or damaged outer tube	Replace the outer tube.
	Damaged or worn slide metal	Replace the slide metal.
	Bent or damaged damper rod	Replace the damper rod.
	Bent wheel axle	Replace the wheel axle.
	Incorrect oil viscosity (high)	Change to recommended fork oil.
	Incorrect oil level (high)	Adjust to the specified oil level.
	Improperly adjusted spring preload (hard)	Adjust the spring preload.
	Improperly adjusted rebound damping (hard)	Adjust the rebound damping.
	Improperly adjusted compression damping (hard)	Adjust the compression damping.

TROUBLESHOOTING

Symptom	Possible cause	Actions
Front fork is soft	Fatigued or broken fork spring	Replace the fork spring.
	Incorrect oil viscosity (low)	Change to recommended fork oil.
	Incorrect oil level (low)	Adjust to the specified oil level.
	Improperly adjusted spring preload (soft)	Adjust the spring preload.
	Improperly adjusted rebound damping (soft)	Adjust the rebound damping.
	Improperly adjusted compression damping (soft)	Adjust the compression damping.
Leaking oil from front fork	Bent, damaged, or corroded inner tube	Replace the inner tube.
	Cracked or damaged outer tube	Replace the outer tube.
	Improperly installed oil seal	Replace the oil seal.
	Damaged oil seal lip	Replace the oil seal.
	Incorrect oil level (high)	Adjust to the specified oil level.
	Loose damper rod assembly bolt	Tighten the damper rod assembly bolt to the specified torque.
	Damaged damper rod assembly bolt copper washer	Replace the damper rod assembly bolt copper washer.
	Cracked or damaged cap bolt O-ring	Replace the cap bolt O-ring.
Rear suspension is hard	Bent or damaged rear shock absorber rod	Replace the rear shock absorber.
	Bent swingarm pivot shaft	Replace the swingarm pivot shaft.
	Damaged or worn swingarm bearing or bushing	Replace the swingarm bearing or bushing.
	Damaged or worn relay arm bearing	Replace the relay arm bearing.
	Damaged or worn connecting arm bearing	Replace the connecting arm bearing.
	Improperly adjusted rear shock absorber spring preload (hard)	Adjust the spring preload.
	Improperly adjusted rear shock absorber rebound damping (hard)	Adjust the rebound damping.
	Improperly adjusted rear shock absorber compression damping (hard)	Adjust the compression damping.

TROUBLESHOOTING

Symptom	Possible cause	Actions
Rear suspension is soft	Oil leaking from rear shock absorber	Replace the rear shock absorber.
	Gas leaking from rear shock absorber	Replace the rear shock absorber.
	Fatigued or damaged rear shock absorber spring	Replace the rear shock absorber.
	Improperly adjusted rear shock absorber spring preload (soft)	Adjust the spring preload.
	Improperly adjusted rear shock absorber rebound damping (soft)	Adjust the rebound damping.
	Improperly adjusted rear shock absorber compression damping (soft)	Adjust the compression damping.
Oil leaking from rear shock absorber	Bent, damaged, or corroded rear shock absorber rod	Replace the rear shock absorber.
	Damaged oil seal lip	Replace the rear shock absorber.

EAM30515

TROUBLESHOOTING OF STEERING/HANDLING

Symptom	Possible cause	Actions
Handlebar wobble	Loose steering ring nut	Tighten the steering ring nut to the specified torque.
	Worn bearing or bearing race	Replace the bearing and bearing race as a set.
	Warped front fork	Repair or replace the front fork.
	Bent front wheel axle	Replace the front wheel axle.
	Incorrect tire pressure	Adjust to the specified tire pressure.
	Worn, deformed, or incorrect tire	Replace the tire.
Heavy steering	Steering ring nut is tightened too tight.	Tighten the steering ring nut to the specified torque.
	Bent lower bracket	Replace the lower bracket.
	Broken bearing or bearing race	Replace the bearing and bearing race as a set.
	Incorrect tire pressure	Adjust to the specified tire pressure.
Front wheel vibration	Loose spoke	Tighten the spoke and adjust the runout.
	Damaged or worn wheel bearing	Replace the wheel bearing.
	Worn, deformed, or incorrect tire	Replace the tire.
	Loose wheel axle or wheel axle nut	Tighten the wheel axle or wheel axle nut to the specified torque.
	Loose wheel axle pinch bolt	Tighten the wheel axle pinch bolt to the specified torque.
	Incorrect front fork oil level	Adjust to the specified front fork oil level.

TROUBLESHOOTING

Symptom	Possible cause	Actions
Rear wheel vibration	Loose spoke	Tighten the spoke and adjust the runout.
	Damaged or worn wheel bearing	Replace the wheel bearing.
	Worn, deformed, or incorrect tire	Replace the tire.
	Loose wheel axle nut	Tighten the wheel axle nut to the specified torque.
	Loose swingarm pivot shaft	Tighten the swingarm pivot shaft to the specified torque.
	Bent or damaged swingarm	Replace the swingarm bearing.
	Damaged or worn swingarm bearing or bushing	Replace the swingarm bearing or bushing.

TUNING

ENGINE	8-1
CARBURETOR SETTING.....	8-1
ATMOSPHERIC CONDITIONS AND CARBURETOR SETTINGS.....	8-1
TEST RUN.....	8-1
EFFECTS OF THE SETTING PARTS ON THE THROTTLE VALVE OPENING	8-2
MAIN JET ADJUSTMENT	8-2
ADJUSTING THE POWER JET	8-2
PILOT AIR SCREW ADJUSTMENT.....	8-2
PILOT JET ADJUSTMENT.....	8-3
JET NEEDLE ADJUSTMENT.....	8-3
JET NEEDLE GROOVE POSITION ADJUSTMENT.....	8-4
RELATIONSHIP WITH THROTTLE OPENING	8-4
CARBURETOR SETTING PARTS.....	8-5
ROAD CONDITION AND EXAMPLES OF CARBURETOR SETTING	8-7
EXAMPLES OF CARBURETOR SETTING DEPENDING ON SYMPTOM	8-7
CHANGE OF THE HEAT RANGE OF SPARK PLUGS	8-9
CHASSIS	8-10
SELECTION OF THE SECONDARY REDUCTION RATIO (SPROCKET)	8-10
DRIVE AND REAR WHEEL SPROCKETS SETTING PARTS	8-10
TIRE PRESSURE.....	8-10
FRONT FORK SETTING.....	8-11
CHANGE IN AMOUNT AND CHARACTERISTICS OF FORK OIL.....	8-11
SETTING OF SPRING AFTER REPLACEMENT	8-11
FRONT FORK SETTING PARTS.....	8-12
REAR SUSPENSION SETTING	8-12
CHOOSING SET LENGTH	8-12
SETTING OF SPRING AFTER REPLACEMENT	8-13
REAR SHOCK ABSORBER SETTING PARTS	8-13
SUSPENSION SETTING (FRONT FORK).....	8-15
SUSPENSION SETTING (REAR SHOCK ABSORBER)	8-16

EAM20198

ENGINE

EAM30590

CARBURETOR SETTING

- The role of fuel is to cool the engine, and in the case of a 2-stroke engine, to lubricate the engine in addition to power generation. Accordingly, if a mixture of air and fuel is too lean, abnormal combustion will occur, and engine seizure may result. If the mixture is too rich, spark plugs will get wet with oil, thus making it impossible to bring the engine into full play or if the worst comes to the worst, the engine may stall.
- The richness of the air-fuel mixture required for the engine will vary with atmospheric conditions of the day and therefore, the settings of the carburetor must be properly suited to the atmospheric conditions (air pressure, humidity and temperature).
- Finally, the rider himself must make a test run and check his vehicle for conditions (pick-up of engine speed, road surface conditions) and for the discoloration of the spark plug(s). After taking these into consideration, he must select the best possible carburetor settings.

TIP

It is advisable to make a note of settings, atmospheric conditions, road surface condition, lap-time, etc. so that the memorandum can be used as a reference useful for future.

EAM30591

ATMOSPHERIC CONDITIONS AND CARBURETOR SETTINGS

Air temp.	Humidity	Air pressure (altitude)	Mixture	Setting
High	High	Low (high)	Richer	Leaner
Low	Low	High (low)	Leaner	Richer

The air density (i.e., concentration of oxygen in the air) determines the richness or leanness of the air/fuel mixture. Therefore, refer to the above table for mixture settings.

That is:

- Higher temperature expands the air with its resultant reduced density.
- Higher humidity reduces the amount of oxygen in the air by so much of the water vapor in the same air.

- Lower atmospheric pressure (at a high altitude) reduces the density of the air.

EAM30592

TEST RUN

After warming up the engine equipped with the standard type carburetor(s) and spark plug(s), run two or three laps of the circuit and check the smooth operation of the engine and discoloration of spark plug(s).

Discoloration	Condition of spark plug
Normal	Insulator is dry and burnt brown.
Over burned (too lean)	Insulator is whitish.
Oil fouled (too rich)	Insulator is sooty and wet.

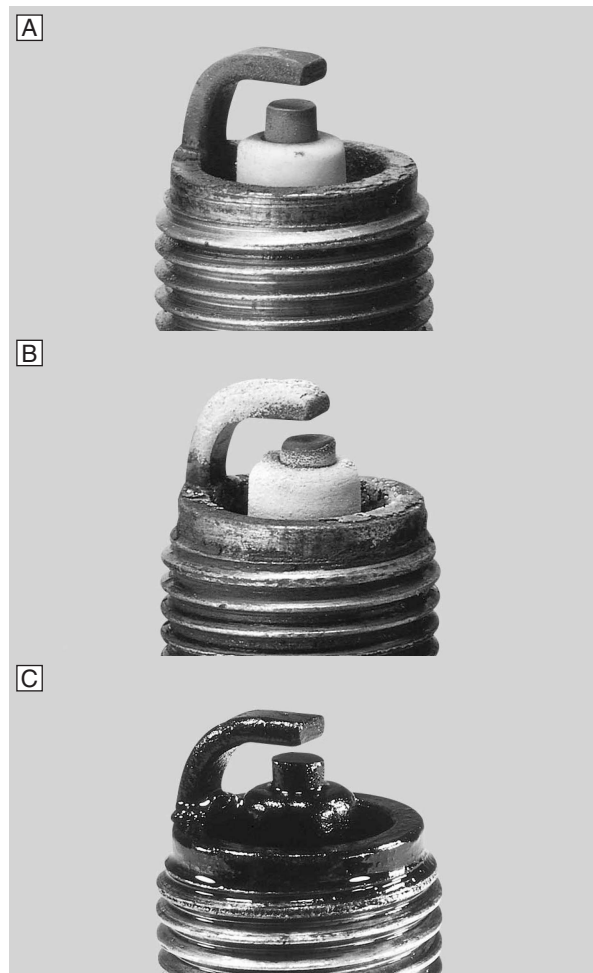

- A. Normal
- B. Over burned (too lean)
- C. Oil fouled (too rich)

EAM30593

EFFECTS OF THE SETTING PARTS ON THE THROTTLE VALVE OPENING

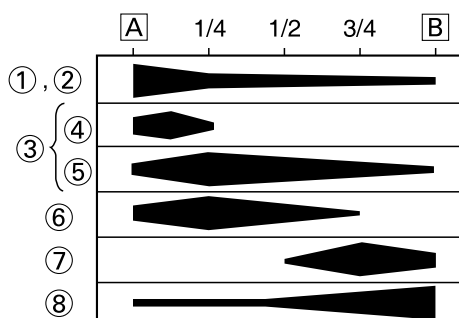
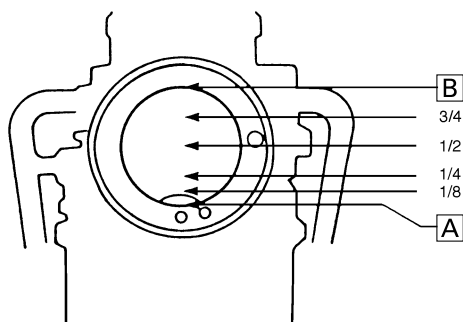

- A. Closed
- B. Full-open

- 1. Pilot jet
- 2. Pilot air screw
- 3. Jet needle
- 4. Diameter of straight portion
- 5. Clip position
- 6. Throttle valve
- 7. Power jet
- 8. Main jet

TIP

The power jet closes at 8500 r/min of the engine, after which only the main jet dominates.

EAM30594

MAIN JET ADJUSTMENT

The richness of air-fuel mixture with 3/4–4/4 throttle can be set by changing the main jet “1”.

Standard main jet	#178
--------------------------	-------------

1. Spark plug is too hot.
Select a main jet having higher calibrating No. than standard. (To be enriched)
2. Spark plug is wet.
Select a main jet having lower calibrating No. than standard. (To be leaned out)

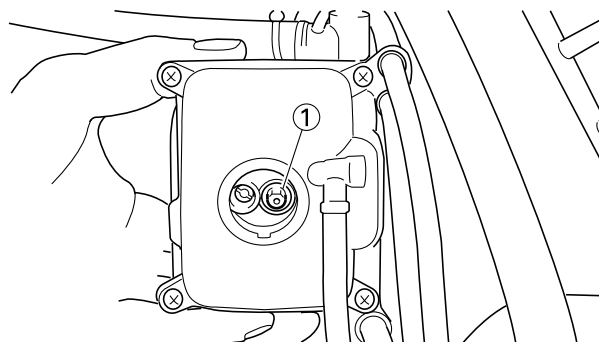

EAM30604

ADJUSTING THE POWER JET

The richness of air-fuel mixture under 8500 r/min to the extent of 1/2 to full opened throttle can be set by changing the power jet “1”. A larger size jet results in a richer mixture, and a smaller size in a leaner mixture.

Standard power jet	#55
---------------------------	------------

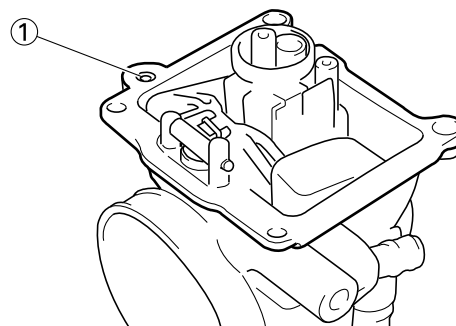

EAM30595

PILOT AIR SCREW ADJUSTMENT

The richness of the air-fuel mixture with the throttle fully closed to 1/8 open can be set by turning the pilot air screw “1”.

Turning in the pilot air screw will make the mixture enrich at low speeds, and turning it out will lean it.

Standard pilot air screw position	1-1/8 turns out
--	------------------------

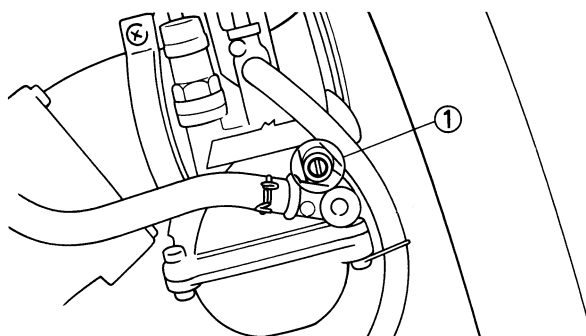

EAM30596

PILOT JET ADJUSTMENT

The richness of air-fuel mixture with the throttle fully closed to 1/2 open can be set by turning the pilot jet "1". It is changed when adjustment cannot be made by the pilot air screw alone.

A larger size jet results in a richer mixture at low speeds, and a smaller size in a leaner mixture.

Standard pilot jet	#52
---------------------------	------------

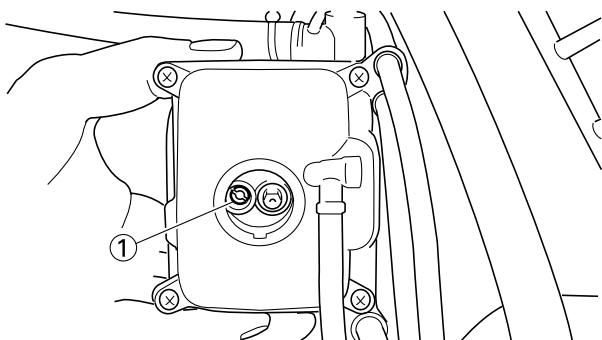

EAM30597

JET NEEDLE ADJUSTMENT

On the carburetors used in the YZ250X, the main nozzle is press-fitted, so it can not be replaced. Therefore, carburetor setting requires the change of the jet needle.

- The jet needle setting parts, having the same taper angle, are available in different straight portion diameters and in different taper starting positions.

Standard jet needle	NYHW
----------------------------	-------------

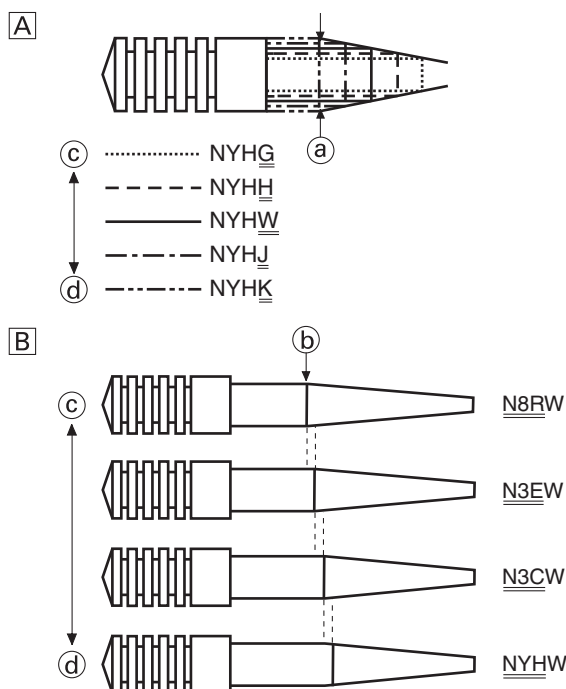

- Difference in straight portion diameter
- Difference in taper starting position

- Diameter of the straight portion
- Taper starting position
- Rich
- Lean

- Effects of changing the jet needle (reference)

- Diameter of straight portion
Changing the diameter of the straight portion adjusts the air-fuel mixture when the throttle is 1/8 to 1/4 open.
- Taper starting position
Changing the taper starting position produces the same effect as changing the clip position by 0.5 groove.

Example:

In case of being 0.5 groove leaner in relation to NYHW-2nd groove, choose N3CW-1st groove.

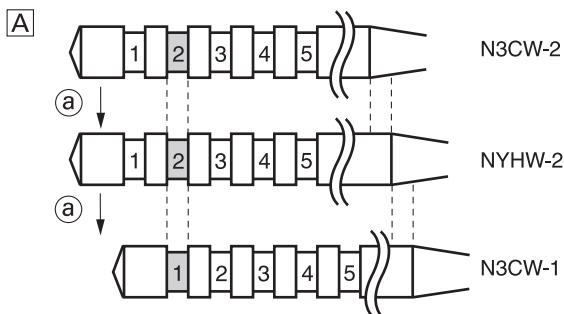

A. In case of being 0.5 groove leaner in relation to NYHW-2nd groove.

a. Difference of 0.5 groove

EAM30598

JET NEEDLE GROOVE POSITION ADJUSTMENT

Should the engine be hard to run smoothly at intermediate speeds, the jet needle "1" must be adjusted. If the mixture is too rich or too lean at intermediate speed operation, irregular engine operation and poor acceleration will result. Whether or not the richness of the mixture is proper is hard to be determined by means of the spark plug and therefore, it should be judged from your feeling of actual engine operation.

Standard clip position	No. 2 groove
------------------------	--------------

1. Too rich at intermediate speeds
Rough engine operation is felt and the engine will not pick up speed smoothly.
In this case, step up the jet needle clip by one groove and move down the needle to lean out the mixture.
2. Too lean at intermediate speeds
The engine breathes hard and will not pick up speed quickly.
In this case, step down the jet needle clip by one groove and move up the needle to enrich the mixture.

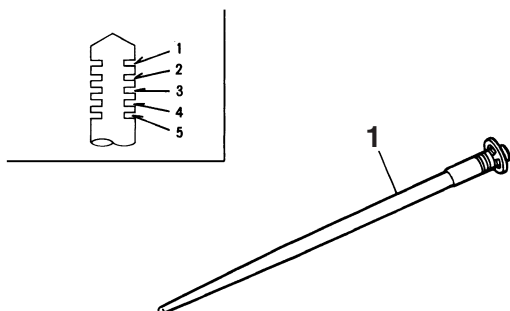

EAM30605

RELATIONSHIP WITH THROTTLE OPENING

The flow of the fuel through the carburetor main system is controlled by the main jet and then, it is further regulated by the area between the main nozzle and the jet needle. On the relationship between the fuel flow and the throttle opening, the fuel flow relates to the jet needle straight portion diameter around 1/8 to 1/4 throttle opening, whereas around 1/4 to 1/1 throttle opening it relates to the taper starting position and to the clip position.

Therefore, the fuel flow is balanced at each stage of throttle opening by the combination of the jet needle straight portion diameter, taper starting position and clip position.

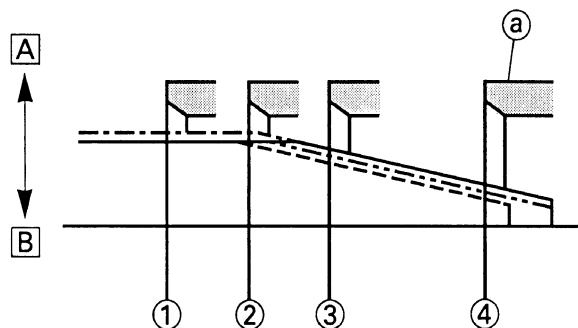

Example:

—————	NYHW-2	- - - - -	NYHJ-2
-----	NYHW-3	-----	N3CW-2

- A. Lean (larger diameter)
B. Rich (smaller diameter)

1. 1/8 throttle
2. 1/4 throttle
3. 1/2 throttle
4. 1/1 throttle

a. Main nozzle

ENGINE

EAM30599

CARBURETOR SETTING PARTS

Part name	Size	Part number		
Main jet "1"	Rich	#190 4MX-14943-45		
		#188 4MX-14943-95		
		#185 4MX-14943-44		
		#182 4MX-14943-94		
		#180 4MX-14943-43		
		(STD) #178 4MX-14943-93		
		#175 4MX-14943-42		
	Lean	#172 4MX-14943-92		
		#170 4MX-14943-41		
		#168 4MX-14943-91		
		#165 4MX-14943-40		
		#162 4MX-14943-90		
		Pilot jet "2"	Rich	#62 4MX-14948-12
				#60 4MX-14948-11
#58 4MX-14948-10				
#55 4MX-14948-09				
(STD) #52 4MX-14948-08				
Lean	#50 4MX-14948-07			
	#48 4MX-14948-06			
	#45 4MX-14948-05			
	#42 4MX-14948-04			
	#40 4MX-14948-03			
	#38 4MX-14948-02			

Part name	Size	Part number
Jet needle "3"	Rich	N3CG 4SR-14916-CG
		N3EG 4SR-14916-EG
		NYHG BRY-14916-HG
		N8RH 4SR-14916-RH
		N3EH 4SR-14916-EH
		N3CH 4SR-14916-CH
		NYHH BRY-14916-HH
		N8RW 4SR-14916-RW
		N3EW 4SR-14916-EW
		N3CW 4SR-14916-CW
	(STD)	NYHW BRY-14916-HW
		N8RJ 4SR-14916-RJ
		N3EJ 4SR-14916-EJ
		N3CJ 4SR-14916-CJ
		NYHJ BRY-14916-HJ
		N3EK 4SR-14916-EK
		Lean N3CK 4SR-14916-CK
Power Jet "4"	Rich	#70 4JT-1494F-15
		#65 4JT-1494F-13
		#60 4JT-1494F-11
	(STD)	#55 4JT-1494F-09
		#50 4JT-1494F-07
		Lean #40 4JT-1494F-03

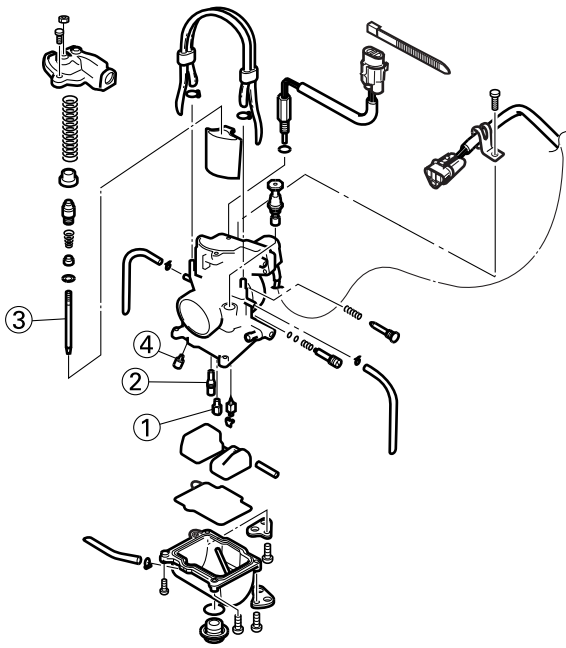

EAM30601

ROAD CONDITION AND EXAMPLES OF CARBURETOR SETTING

	General condition			Sandy condition		
	Under 10 °C (50 °F) (Winter)	15–25 °C (59–77 °F) (Spring, Autumn)	Over 25 °C (77 °F) (Summer)	Under 10 °C (50 °F) (Winter)	15–25 °C (59–77 °F) (Spring, Autumn)	Over 25 °C (77 °F) (Summer)
Main jet	#178	#178	#178	#182	#180	#180
Jet needle	NYHW-2	NYHW-2	NYHW-2	N3CW-2	N3CW-2	NYHW-2
Pilot jet	#52	#52	#50	#52	#52	#50
Pilot air screw	-1/4	0	0	0	0	0
Power jet	#55	#55	#55	#55	#55	#55

TIP

Optimum pilot air screw setting can be obtained by adding the ex-factory number of the same screw back-out turns to any required value provided in the chart. For example, if the ex-factory number is “1”, add “1” to the value chosen in the chart.

EAM30602

EXAMPLES OF CARBURETOR SETTING DEPENDING ON SYMPTOM

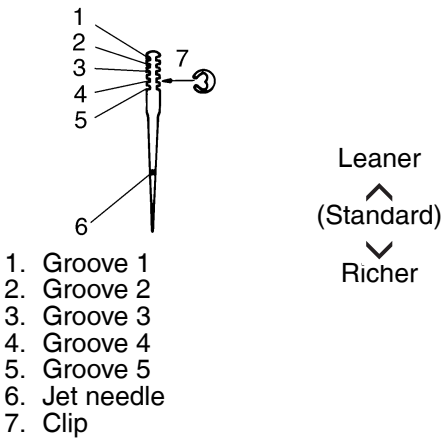
Symptom	Setting	Checking
<ul style="list-style-type: none"> At full throttle Stall at high speeds *Hard breathing Shearing noise Whitish spark plug ↓ Lean mixture 	Increase main jet calibration no. (Gradually)	<ul style="list-style-type: none"> Discoloration of spark plug → If tan color, it is in good condition. If cannot be corrected: <ul style="list-style-type: none"> Clogged float valve seat Clogged fuel hose Clogged fuel cock
<ul style="list-style-type: none"> At full throttle Speed pick-up stops Slow speed pick-up Slow response Sooty spark plug ↓ Rich mixture 	Decrease main jet calibration no. (Gradually) *In case of racing slight enrichment of mixture reduces engine trouble.	<ul style="list-style-type: none"> Discoloration of spark plug → If tan color, it is in good condition. If cannot be corrected: <ul style="list-style-type: none"> Clogged air filter Fuel overflow from carburetor
Lean mixture	Lower jet needle clip position. (1 groove down)	
Rich mixture	Raise jet needle clip position. (1 groove up)	
<ul style="list-style-type: none"> 1/4–3/4 throttle *Hard breathing Lack of speed 	Lower jet needle clip position. (1 groove down)	
<ul style="list-style-type: none"> 1/4–1/2 throttle Slow speed pick-up White smoke Poor acceleration 	Raise jet needle clip position. (1 groove up)	The clip position is the jet needle groove on which the clip is installed. The positions are numbered from the top.

ENGINE

Symptom	Setting	Checking
<ul style="list-style-type: none"> Closed to 1/4 throttle *Hard breathing Speed down 	Use jet needle having a smaller diameter.	
<ul style="list-style-type: none"> Closed to 1/4 throttle Poor acceleration White smoke 	Use jet needle with a larger diameter.	
<ul style="list-style-type: none"> Unstable at low speeds Pinking noise 	Lower jet needle clip position. (1 groove down) Turn in pilot air screw.	
Poor response at extremely low speed	Reduce pilot jet calibration No. Turn out pilot air screw. If not effect, reverse the above procedures.	Dragging brake Overflow from carburetor
Poor response in the low to intermediate speeds	Raise jet needle clip position. If no effect, reverse the above procedures.	
Poor response when throttle is opened quickly	Check overall settings. Use main jet having lower calibration No. Raise jet needle clip position. (1 groove up) If no effect, reverse the above procedures.	Check air filter for fouling.
Poor engine operation	Turn in pilot air screw.	Check throttle valve operation.

* marked: In case of hard breathing, check the carburetor breather hoses for clogging.

This should be taken simply for an example. It is necessary to set the carburetor while checking the operating conditions of the engine and discoloration of spark plugs.

Normally, carburetor setting is made by means of the main jet, jet needle clip position, pilot jet and pilot air screw.

EAM30603

CHANGE OF THE HEAT RANGE OF SPARK PLUGS

Judging from the discoloration of spark plugs, if they are found improper, it can be corrected by the following two methods; changing carburetor settings and changing the heat range of spark plug.

Standard spark plug	BR8EG (resistance type)
---------------------	----------------------------

- In principle, it is advisable to first use spark plugs of standard heat range, and judging from the discoloration of spark plugs, adjust carburetor settings.
- If the calibration No. of the main jet must be changed by ± 15 , it is advisable to change the heat range of spark plugs and newly select the proper main jet.

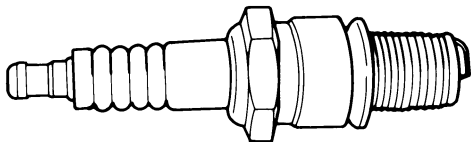

TIP

- When checking the discoloration of spark plugs, be sure to stop the engine immediately after a run and check.
- Avoid racing.
- When changing the heat range of spark plugs, never attempt to change it more than ± 1 rank.
- When using a spark plug other than standard, check its heat range against the standard and check that it is a resistance type.
- Note that even if the discoloration seems proper, it may slightly vary with the spark plug maker and oil in use.

EAM20119

CHASSIS

EAM30168

SELECTION OF THE SECONDARY REDUCTION RATIO (SPROCKET)

Secondary reduction ratio = Number of rear wheel sprocket teeth/Number of drive sprocket teeth



**Secondary reduction ratio
3.571 (50/14)**

<Requirement for selection of secondary gear reduction ratio>

- It is generally said that the secondary gear ratio should be reduced for a longer straight portion of a speed course and should be increased for a course with many corners. Actually, however, as the speed depends on the ground condition of the day of the race, be sure to run through the circuit to set the machine suitable for the entire course.
- In actuality, it is very difficult to achieve settings suitable for the entire course and some settings may be sacrificed. Thus, the settings should be matched to the portion of the course that has the greatest effect on the race result. In such a case, run through the entire course while making notes of lap times to find the best balance; then, determine the secondary reduction ratio.
- If a course has a long straight portion where a machine can run at maximum speed, the machine is generally set such that it can develop its maximum revolutions toward the end of the straight line, with care taken to avoid the engine over-revving.

TIP

Riding technique varies from rider to rider and the performance of a machine also vary from machine to machine. Therefore, do not imitate other rider's settings from the beginning but choose your own setting according to the level of your riding technique.

EAM30169

DRIVE AND REAR WHEEL SPROCKETS SETTING PARTS

Part name	Type	Part number
Drive sprocket "1"	13T	9383E-13216
	(STD) 14T	9383E-14215
Rear wheel sprocket "2"	47T	17D-25447-50
	48T	17D-25448-50
	49T	B2W-25449-00
	(STD) 50T	B2W-25450-00
	51T	B2W-25451-00
	52T	17D-25452-50

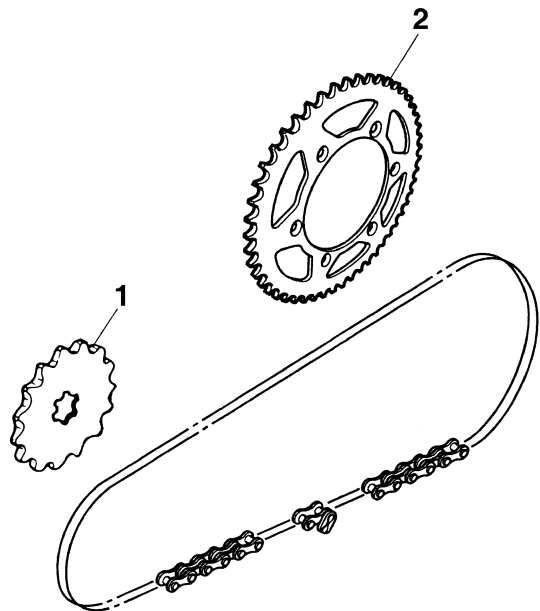

EAM30170

TIRE PRESSURE

Tire pressure should be adjusted to suit the road surface condition of the circuit.



**Standard tire pressure
100 kPa (1.00 kgf/cm², 15 psi)**

- Under a rainy, a muddy, a sandy, or a slippery condition, the tire pressure should be lower for a larger area of contact with the road surface.



**Extent of adjustment
60–80 kPa (0.60–0.80 kgf/cm², 9–12 psi)**

- Under a stony or a hard road condition, the tire

pressure should be higher to prevent a flat tire.

	<p>Extent of adjustment 100–120 kPa (1.00–1.20 kgf/cm², 15–18 psi)</p>
---	---

EAM30171

FRONT FORK SETTING

The front fork setting should be made depending on the rider's feeling of an actual run and the circuit conditions.

The front fork setting includes the following three factors:

1. Setting of air spring characteristics
 - Change the fork oil amount.
2. Setting of spring preload
 - Change the spring.
3. Setting of damping force
 - Change the compression damping force.
 - Change the rebound damping force.

The spring acts on the load and the damping force acts on the cushion travel speed.

EAM30172

CHANGE IN AMOUNT AND CHARACTERISTICS OF FORK OIL

Damping characteristic near the final stroke can be changed by changing the fork oil amount.

EWA19190



Adjust the oil amount in 5 cm³ (0.2 US oz, 0.2 Imp.oz) increments or decrements. Too small oil amount causes the front fork to produce a noise at full rebound or the rider to feel some pressure on his hands or body. Alternatively, too large oil amount will cause the air spring characteristics to have a tendency to be stiffer with the consequent deteriorated performance and characteristics. Therefore, adjust the front fork within the specified range.

	<p>Recommended oil Yamaha Suspension Oil S1 Standard oil amount 285 cm³ (9.6 US oz, 10.1 Imp.oz) Extent of adjustment 265–365 cm³ (9.0–12.3 US oz, 9.4–12.9 Imp.oz)</p>
---	---

A

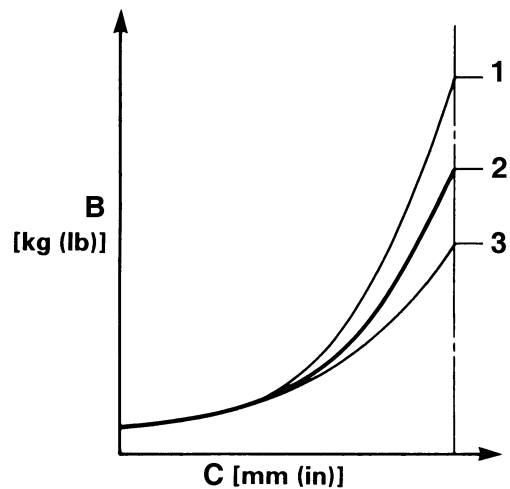

A. Air spring characteristics in relation to oil amount change

B. Load

C. Stroke

1. Max. oil amount
2. Standard oil amount
3. Min. oil amount

EAM30173

SETTING OF SPRING AFTER REPLACEMENT

As the front fork setting can be easily affected by the rear suspension, take care so that the front and the rear are balanced (in position etc.) when setting the front fork.

1. Use of soft spring
 - Change the rebound damping force.
Turn out one or two clicks.
 - Change the compression damping force.
Turn in one or two clicks.

TIP

Generally a soft spring gives a soft riding feeling. Rebound damping tends to become stronger and the front fork may sink deeply over a series of gaps.

2. Use of stiff spring
 - Change the rebound damping force.
Turn in one or two clicks.
 - Change the compression damping force.
Turn out one or two clicks.

TIP

Generally a stiff spring gives a stiff riding feeling. Rebound damping tends to become weaker, resulting in lack of a sense of contact with the road surface or in a vibrating handlebar.

EAM30174

FRONT FORK SETTING PARTS

- Front fork spring

STD spring rate (N/mm)		4.3	
Type	Spring rate (N/mm)	Part number	I.D. mark (slits)
↑	3.9	BRY-23141-00	I
	4.0	BRY-23141-10	II
	4.1	B3J-23141-10	III
	4.2	B3J-23141-20	IIII
	4.3	B3J-23141-30	IIIII
	4.4	B3J-23141-40	I-I
	4.5	BR9-23141-20	I-II
	4.6	BR9-23141-30	I-III
	4.7	BR9-23141-40	I-IIII
	4.8	BR9-23141-50	I-IIIII
↓	4.9	BR9-23141-60	II-II
	5.0	BR9-23141-70	II-III
STIFF	5.1	BR9-23141-80	II-IIIII

TIP

The I.D. mark (slits) is proved on the end of the spring.

EAM30175

REAR SUSPENSION SETTING

The rear shock absorber setting should be made depending on the rider's feeling of an actual run and the circuit conditions.

The rear suspension setting includes the following two factors:

1. Setting of spring preload
 - Change the set length of the spring.
 - Change the spring.
2. Setting of damping force
 - Change the rebound damping force.
 - Change the compression damping force.

EAM30176

CHOOSING SET LENGTH

1. Place a stand or a block under the engine to

put the rear wheel above the floor, and measure the length "a" between the rear wheel axle center and "△" mark of rear fender.

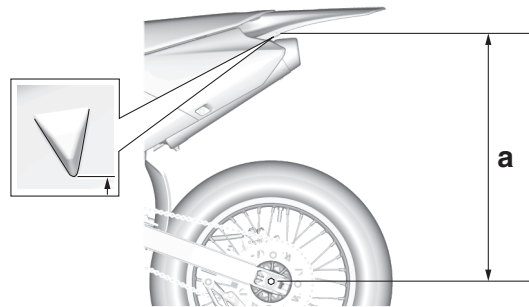

2. Remove the stand or block from the engine and, with a rider astride the seat, measure the sunken length "b" between the rear wheel axle center and "△" mark of rear fender.

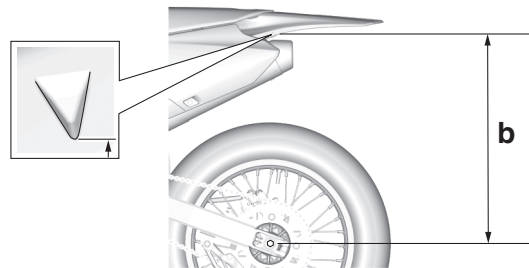

3. Loosen the locknut "1" and make adjustment by turning the adjuster "2" to achieve the standard figure from the subtraction of the length "b" from the length "a".



Standard figure
90–100 mm (3.5–3.9 in)

TIP

- If the machine is new and after it is broken in, the same set length of the spring may change because of the initial fatigue, etc. of the spring. Therefore, be sure to make reevaluation.
- If the standard figure cannot be achieved by adjusting the adjuster and changing the set length, replace the spring with an optional one and make readjustment.

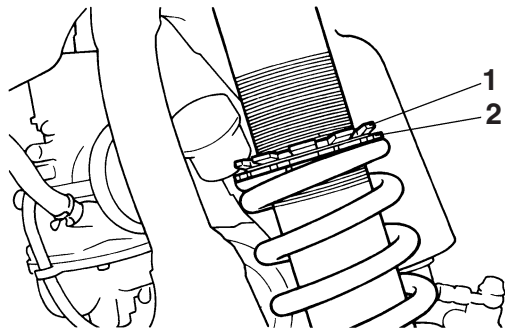

EAM30177

SETTING OF SPRING AFTER REPLACEMENT

After replacement, be sure to adjust the spring to the set length [sunken length 90–100 mm (3.5–3.9 in)] and set it.

1. Use of soft spring

- Adjust to decrease rebound damping force to compensate for less spring load. Run with the rebound damping force adjuster one or two clicks turned out, and readjust it to suit your preference.

2. Use of stiff spring

- Adjust to increase rebound damping force to compensate for greater spring load. Run with the rebound damping force adjuster one or two clicks turned in, and readjust it to suit your preference.

TIP

Adjusting the rebound damping force will be followed more or less by a change in the compression damping force. For correction, adjust to decrease compression damping force.

EWA19200

WARNING

When using a rear shock absorber other than currently installed, use the one whose overall length “a” does not exceed the standard as it may result in faulty performance. Never use one whose overall length is greater than standard.



Length “a” of standard shock
490 mm (19.29 in)

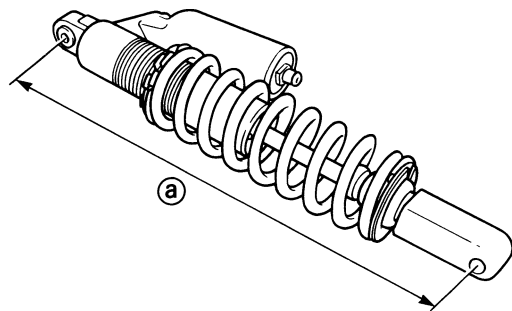

EAM30178

REAR SHOCK ABSORBER SETTING PARTS

- Rear shock spring “1”
[Equal-pitch steel spring]

STD spring rate (N/mm)		48	
Type	Spring rate (N/mm)	Part number	I.D. mark/Q'ty
SOFT ↑	42	5UN-22212-00 (Silver)	Brown/1
	44	5UN-22212-10 (Silver)	Green/1
	46	5UN-22212-20 (Silver)	Red/1
	48	5UN-22212-30 (Silver)	Black/1
	50	5UN-22212-40 (Silver)	Blue/1
	52	5UN-22212-50 (Silver)	Yellow/1
↓ STIFF	54	5UN-22212-60 (Silver)	Pink/1
	56	5UN-22212-70 (Silver)	White/1

[Unequal-pitch steel spring]

- Spring preload adjusting positions

Type	Spring rate (N/mm)	Part number	I.D. mark/Q'ty
SOFT ↑	44	5UN-22212-A0 (Silver)	Green/2
	46	5UN-22212-B0 (Silver)	Red/2
	48	5UN-22212-C0 (Silver)	Black/2
	50	5UN-22212-D0 (Silver)	Blue/2
	52	5UN-22212-E0 (Silver)	Yellow/2
↓ STIFF	54	5UN-22212-F0 (Silver)	Pink/2
	56	5UN-22212-G0 (Silver)	White/2



Spring preload adjusting positions

Minimum

Position in which the spring is turned in 1.5 mm (0.06 in) from its free length.

Standard

Position in which the spring is turned in 8.0 mm (0.31 in) from its free length.

Maximum

Position in which the spring is turned in 18.5 mm (0.73 in) from its free length.

TIP

For the spring preload adjustment, refer to "ADJUSTING THE REAR SHOCK ABSORBER ASSEMBLY" on page 3-20.

TIP

- The unequal-pitch spring is softer in initial characteristic than the equal-pitch spring and is difficult to bottom out under full compression.
- The I.D. mark "a" is marked at the end of the spring.
- Spring specification varies according to the color and quantity of I.D. marks.

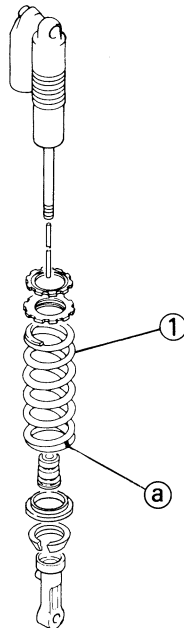

EAM30179

SUSPENSION SETTING (FRONT FORK)

TIP

- If any of the following symptoms is experienced with the standard position as the base, make resetting by reference to the adjustment procedure given in the same chart.
- Before any change, set the rear shock absorber sunken length to the standard figure 90–100 mm (3.5–3.9 in).

Symptom	Section				Check	Adjust
	Jump	Large gap	Medium gap	Small gap		
Stiff over entire range	√	√	√		Compression damping force Oil amount Spring	Turn adjuster counterclockwise (about 2 clicks) to decrease damping. Decrease oil amount by about 5–10 cm ³ (0.2–0.3 US oz, 0.2–0.4 Imp.oz). Replace with soft spring.
Unsmooth movement over entire range	√	√	√	√	Outer tube Inner tube Slide metal Piston metal Lower bracket tightening torque	Check for any bends, dents, other noticeable scars, etc. If any, replace affected parts. Replace with a new one for extended use. Replace with a new one for extended use. Retighten to specified torque.
Poor initial movement				√	Rebound damping force Oil seals	Turn adjuster counterclockwise (about 2 clicks) to decrease damping. Apply grease in oil seal wall.
Soft over entire range, bottoming out	√	√			Compression damping force Oil amount Spring	Turn adjuster clockwise (about 2 clicks) to increase damping. Increase oil amount by about 5–10 cm ³ (0.2–0.3 US oz, 0.2–0.4 Imp.oz). Replace with stiff spring.
Stiff toward stroke end	√				Oil amount	Decrease oil amount by about 5 cm ³ (0.2 US oz, 0.2 Imp.oz).
Soft toward stroke end, bottoming out	√				Oil amount	Increase oil amount by about 5 cm ³ (0.2 US oz, 0.2 Imp.oz).
Stiff initial movement	√	√	√	√	Compression damping force	Turn adjuster counterclockwise (about 2 clicks) to decrease damping.

Symptom	Section				Check	Adjust
	Jump	Large gap	Medium gap	Small gap		
Low front, tending to lower front posture			√	√	Compression damping force Rebound damping force Balance with rear end Oil amount	Turn adjuster clockwise (about 2 clicks) to increase damping. Turn adjuster counterclockwise (about 2 clicks) to decrease damping. Set sunken length for 95–100 mm (3.7–3.9 in) when one passenger is astride seat (lower rear posture). Increase oil amount by about 5 cm ³ (0.2 US oz, 0.2 Imp.oz).
“Obtrusive” front, tending to upper front posture			√	√	Compression damping force Balance with rear end Spring Oil amount	Turn adjuster counterclockwise (about 2 clicks) to decrease damping. Set sunken length for 90–95 mm (3.5–3.7 in) when one passenger is astride seat (upper rear posture). Replace with soft spring. Decrease oil amount by about 5–10 cm ³ (0.2–0.3 US oz, 0.2–0.4 Imp.oz).

EAM30180

SUSPENSION SETTING (REAR SHOCK ABSORBER)

TIP

- If any of the following symptoms is experienced with the standard position as the base, make resetting by reference to the adjustment procedure given in the same chart.
- Adjust the rebound damping in 2-click increments or decrements.
- Adjust the low compression damping in 1-click increments or decrements.
- Adjust the high compression damping in 1/6 turn increments or decrements.

Symptom	Section				Check	Adjust
	Jump	Large gap	Medium gap	Small gap		
Stiff, tending to sink			√	√	Rebound damping force Spring set length	Turn adjuster counterclockwise (about 2 clicks) to decrease damping. Set sunken length for 90–100 mm (3.5–3.9 in) when one passenger is astride seat.
Spongy and unstable			√	√	Rebound damping force Low compression damping Spring	Turn adjuster clockwise (about 2 clicks) to increase damping. Turn adjuster clockwise (about 1 click) to increase damping. Replace with stiff spring.

CHASSIS

Symptom	Section				Check	Adjust
	Jump	Large gap	Medium gap	Small gap		
Heavy and dragging			√	√	Rebound damping force Spring	Turn adjuster counterclockwise (about 2 clicks) to decrease damping. Replace with soft spring.
Poor road gripping				√	Rebound damping force Low compression damping High compression damping Spring set length Spring	Turn adjuster counterclockwise (about 2 clicks) to decrease damping. Turn adjuster clockwise (about 1 click) to increase damping. Turn adjuster clockwise (about 1/6 turn) to increase damping. Set sunken length for 90–100 mm (3.5–3.9 in) when one passenger is astride seat. Replace with soft spring.
Bottoming out	√	√			High compression damping Spring set length Spring	Turn adjuster clockwise (about 1/6 turn) to increase damping. Set sunken length for 90–100 mm (3.5–3.9 in) when one passenger is astride seat. Replace with stiff spring.
Bouncing	√	√			Rebound damping force Spring	Turn adjuster clockwise (about 2 clicks) to increase damping. Replace with soft spring.
Stiff travel	√	√			High compression damping Spring set length Spring	Turn adjuster counterclockwise (about 1/6 turn) to decrease damping. Set sunken length for 90–100 mm (3.5–3.9 in) when one passenger is astride seat. Replace with soft spring.



PRINTED IN JAPAN
(E)



PRINTED IN JAPAN
2022.05-0.1×1 
(E, F)